

# The Quark-Gluon Plasma

Characterizing the early Universe matter with the first 10 years of heavy-ion collisions at the LHC

Anton Andronic

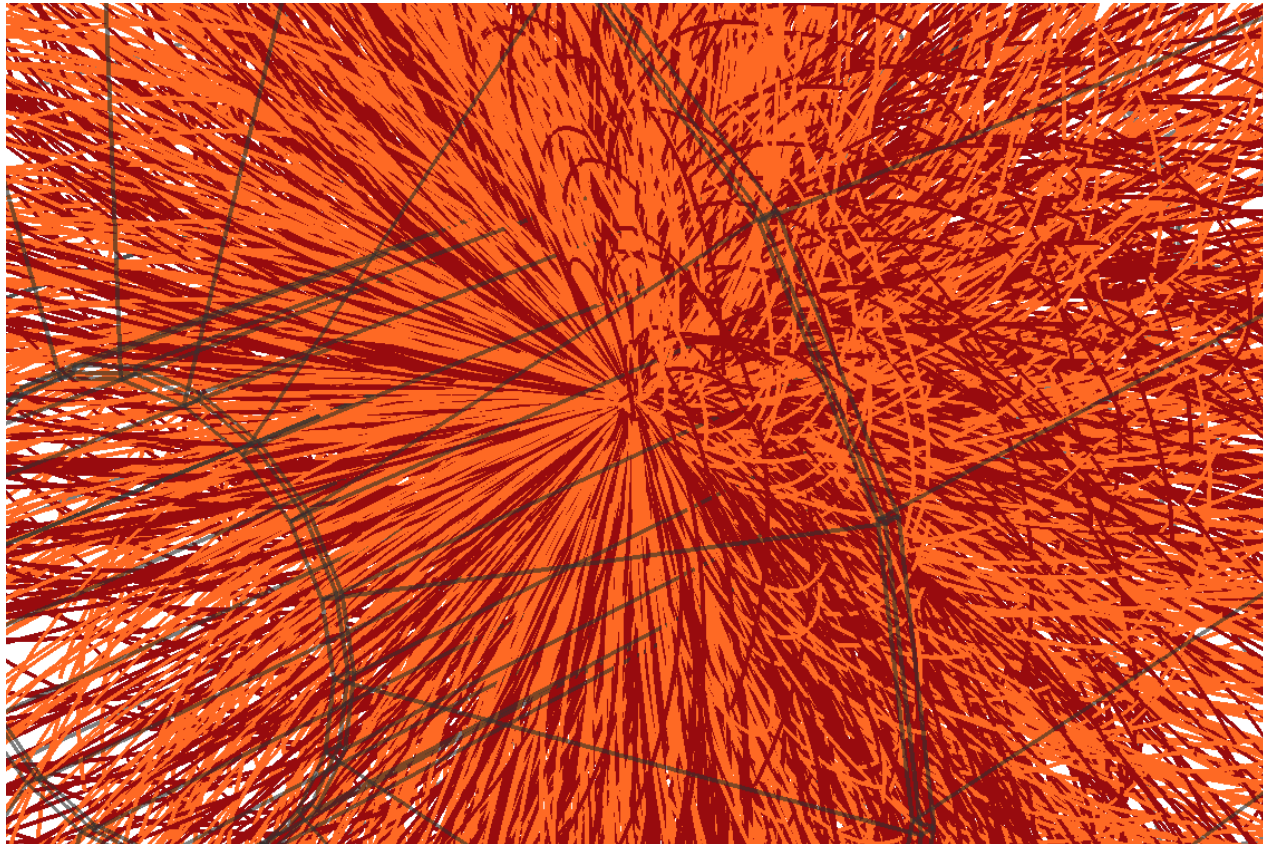

# Outline

---

- Introduction, theoretical basis
- The LHC and the detectors; what is measured
- Hadrons with light-flavor (u,d,s) and the QCD phase diagram
- Collective flow, hydrodynamics
- Jet quenching (parton energy loss)
- Heavy quarks and deconfined matter
- Summary

see reviews: AA, [arXiv:1407.5003](#); Busza, Rajagopal, van der Schee, [1802.04801](#)

# The proton at high resolution (energies)

A. Andr

3

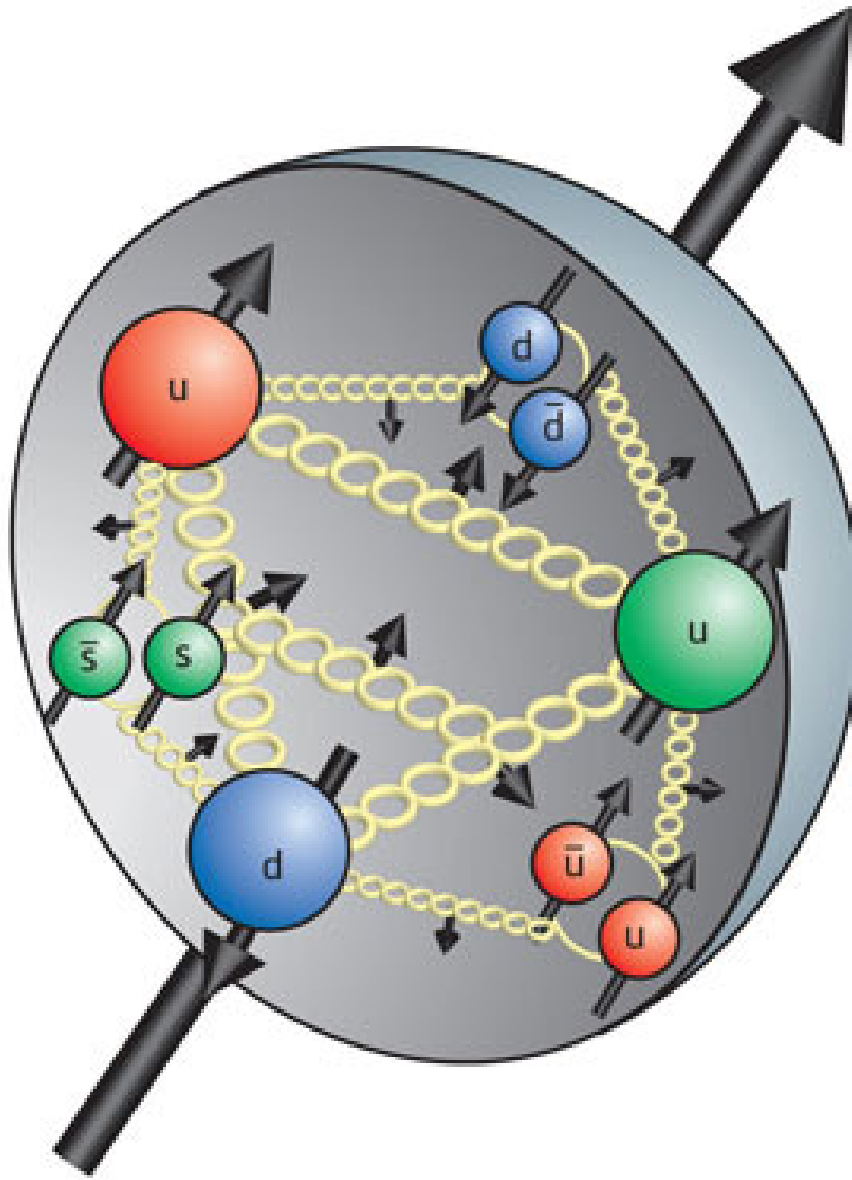

There are more quarks than the “constituent” (valence)  $u, u, d$   
...virtual quark-antiquark pairs; also many gluons

This is one of many possible configurations

...obtained in (deep-inelastic) electron scattering experiments with resolution  $10^{-18}$ - $10^{-19}$  m (leading to “parton distribution functions”)

The quarks are never found free  
*quark confinement* (principle)

...are free only asymptotically ( $Q \rightarrow \infty$ )

Gross, Wilczek, Politzer, 1974 (Nobel Prize 2004)

...has led to the proposal of the Quark-Gluon Plasma (high  $T$ )

Collins & Perry, Cabibbo & Parisi, 1975 (Itoh, 1970; Carruthers, 1973; Shuryak)

# Lattice QCD predicts a phase transition ( $\mu_B=0$ )

A. Andronic

4

numerical solutions of QCD on a discrete (space-time) grid (sophisticated formalism, huge computers)

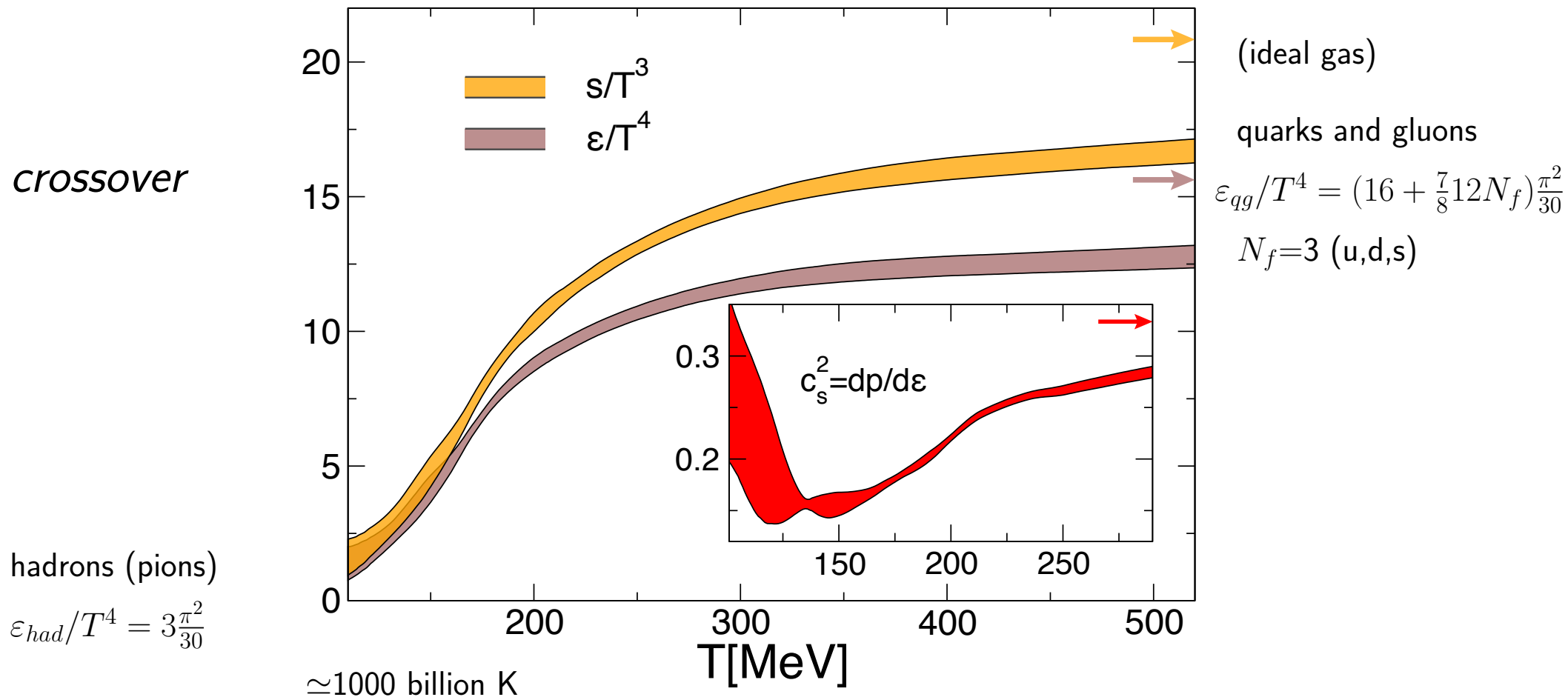

Borsanyi et al., [PLB 370 \(2014\) 99](#) , [PRL 125 \(2020\) 052001](#) ; Bazavov et al., [PLB 795 \(2019\) 15](#)

$T_c = 156.5 \pm 1.5$  ( $158.0 \pm 0.6$ ) MeV,  $\varepsilon_c \simeq 0.4$  GeV/fm<sup>3</sup>, or  $2.5\varepsilon_{nuclear}$

ideal-gas limit not reached at very large temperatures (GeV range explored)

# HISTORY OF THE UNIVERSE

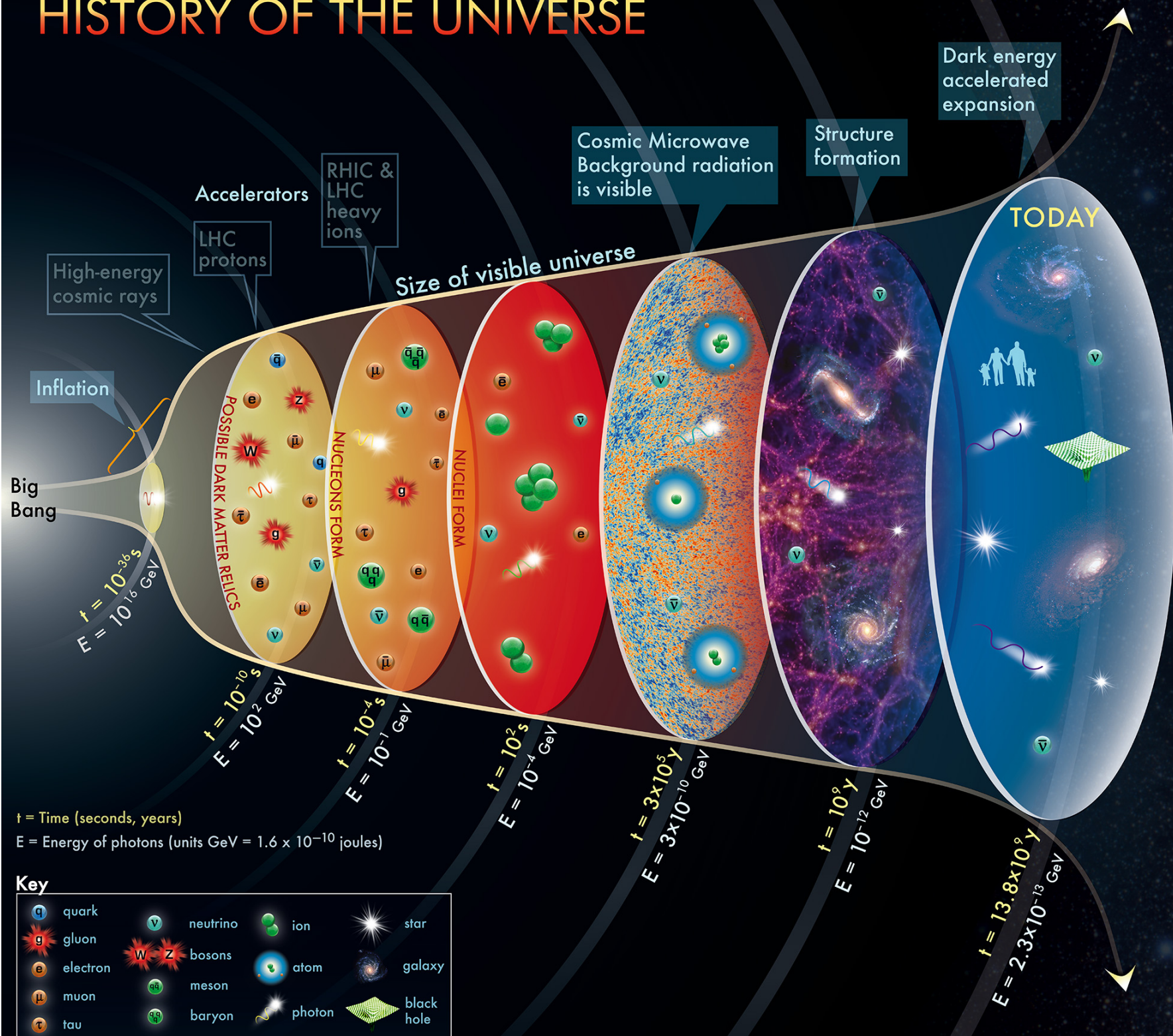

## Key

quark	neutrino	ion	star
gluon	bosons	atom	galaxy
electron	meson	photon	black hole
muon	baryon		
tau			

# How to "simulate" in laboratory the early Universe?

A. Andronic

6

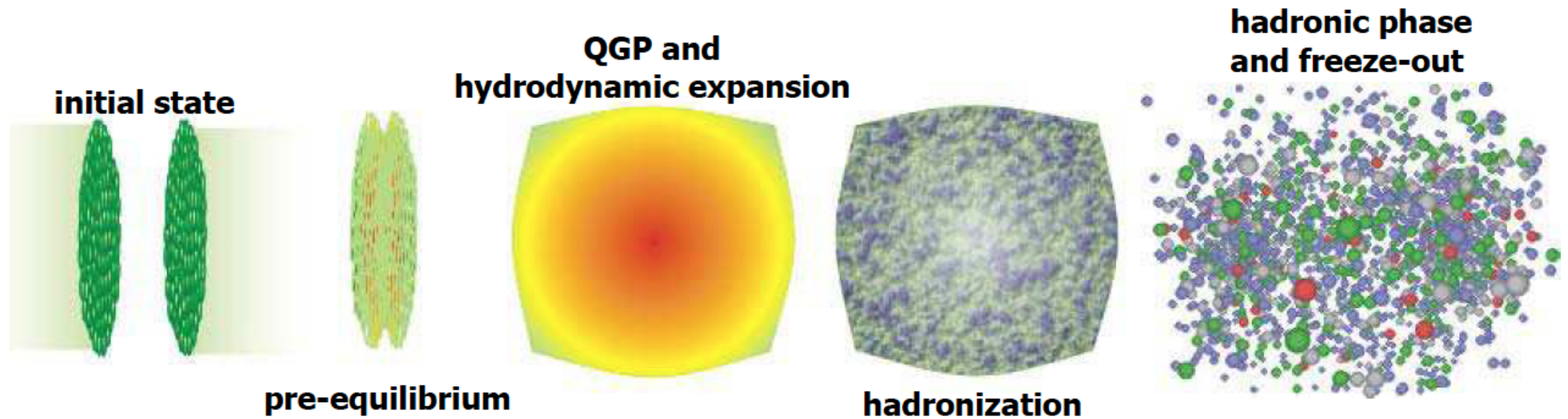

$$\underline{t \simeq 10^{-23} \text{ s}, V \simeq 10^{-40} \text{ m}^3}$$

1. initial collisions ( $t \leq t_{coll} = 2R/\gamma_{cm}c$ ;  $R_{Pb} \simeq 7 \text{ fm}$ )
2. thermalization: equilibrium is established ( $t \lesssim 1 \text{ fm}/c = 3 \times 10^{-24} \text{ s}$ )
3. expansion ( $\sim 0.6c$ ) and cooling ( $t < 10\text{-}15 \text{ fm}/c$ ) ...deconfined stage?
4. hadronization (quarks and gluons form hadrons)
5. chemical freeze-out: inelastic collisions cease; particle identities (yields) frozen
6. kinetic freeze-out: elastic collisions cease; spectra are frozen ( $t_+ = 3\text{-}5 \text{ fm}/c$ )

# The CERN accelerator complex

## Complexe des accélérateurs du CERN

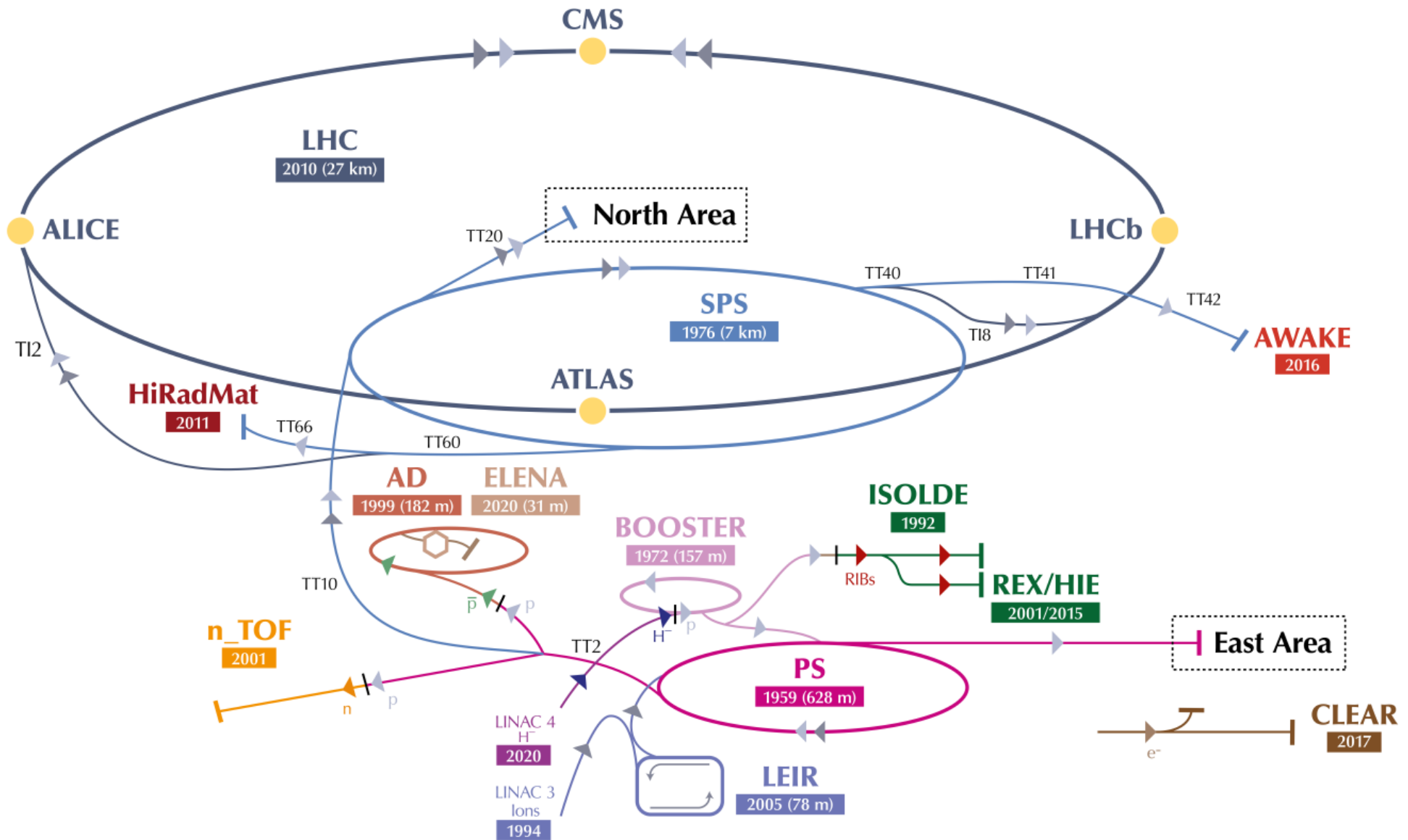

▶  $H^-$  (hydrogen anions)   ▶ p (protons)   ▶ ions   ▶ RIBs (Radioactive Ion Beams)   ▶ n (neutrons)   ▶  $\bar{p}$  (antiprotons)   ▶  $e^-$  (electrons)

# The detectors at the LHC all measure heavy-ion collisions

A. Andronic

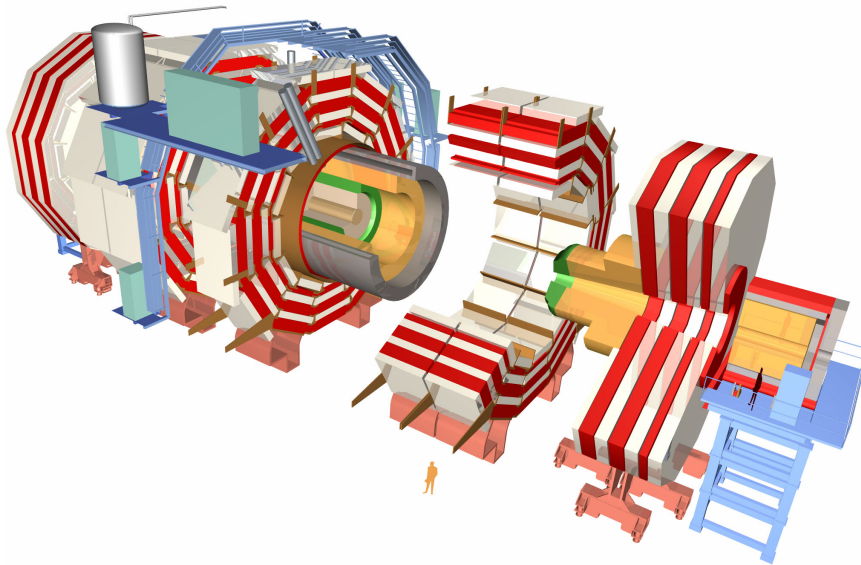

## LHCb experiment

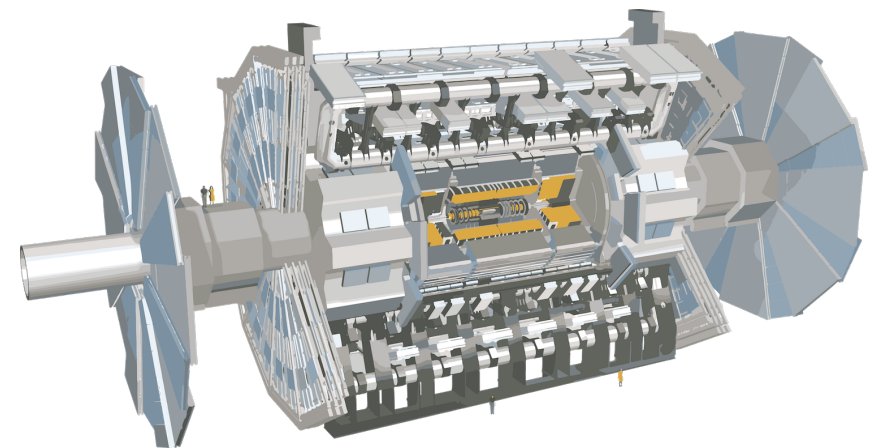
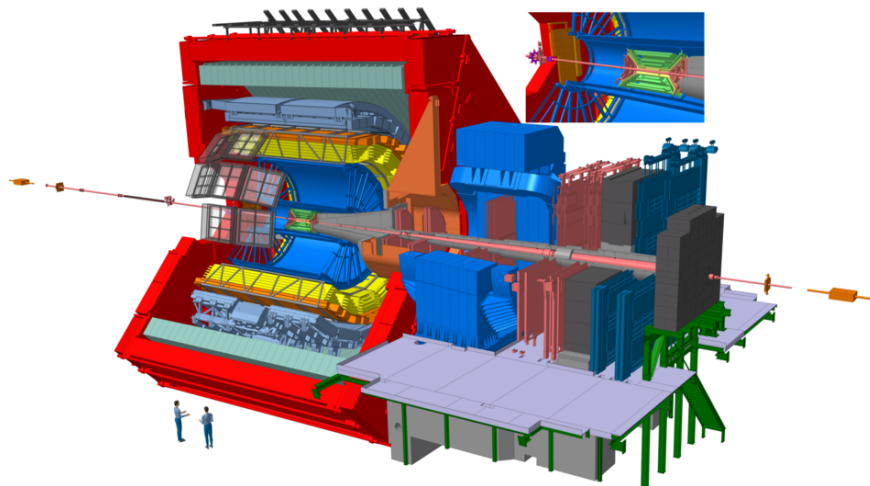
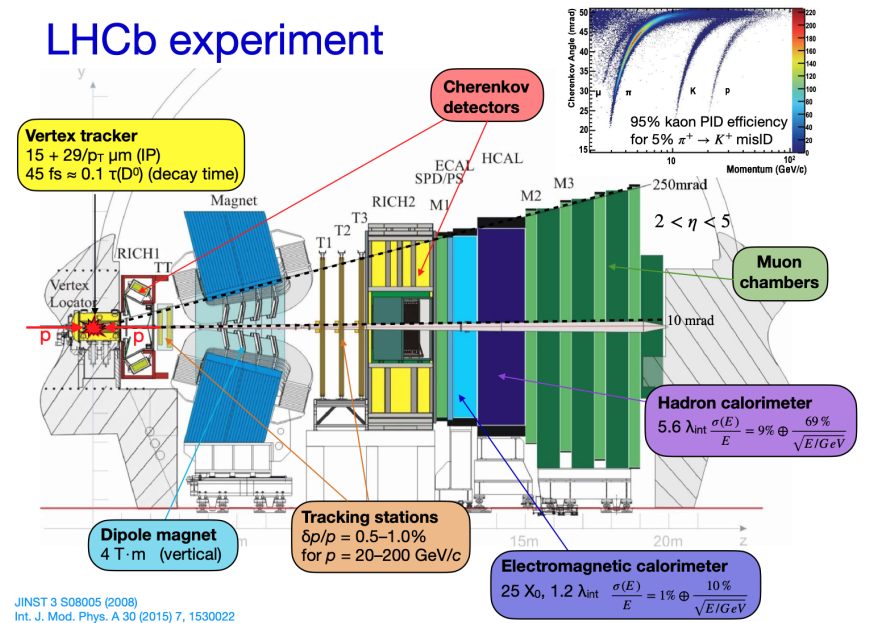



# A detector at the LHC - ALICE

A. Andronic

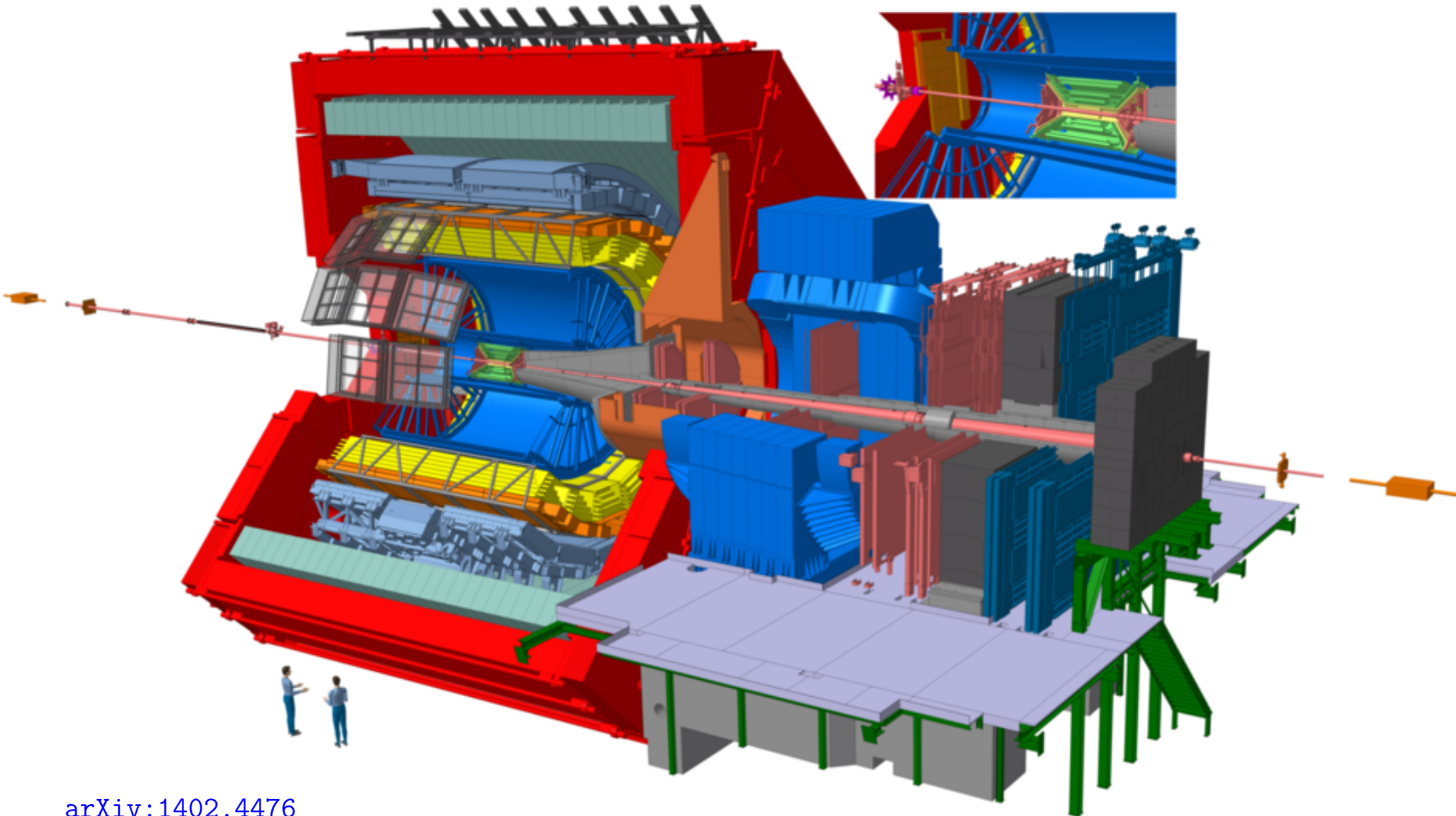

[arXiv:1402.4476](https://arxiv.org/abs/1402.4476)

ALICE Collaboration: 40 countries, 170 institutions, 2009 members

# What are the "control parameters"

- Energy of the collision (per nucleon pair,  $\sqrt{s_{NN}}$ )
- Centrality of the collision (number of "participating" nucleons,  $N_{part}$ )  
[at high energies geometric concepts valid: "participant-spectator" picture]  
measured in percentage of the geometric cross section ( $\sigma_{AB} = \pi(R_A + R_B)^2$ )  
*NB: we sort the collisions offline, based on detector signals*

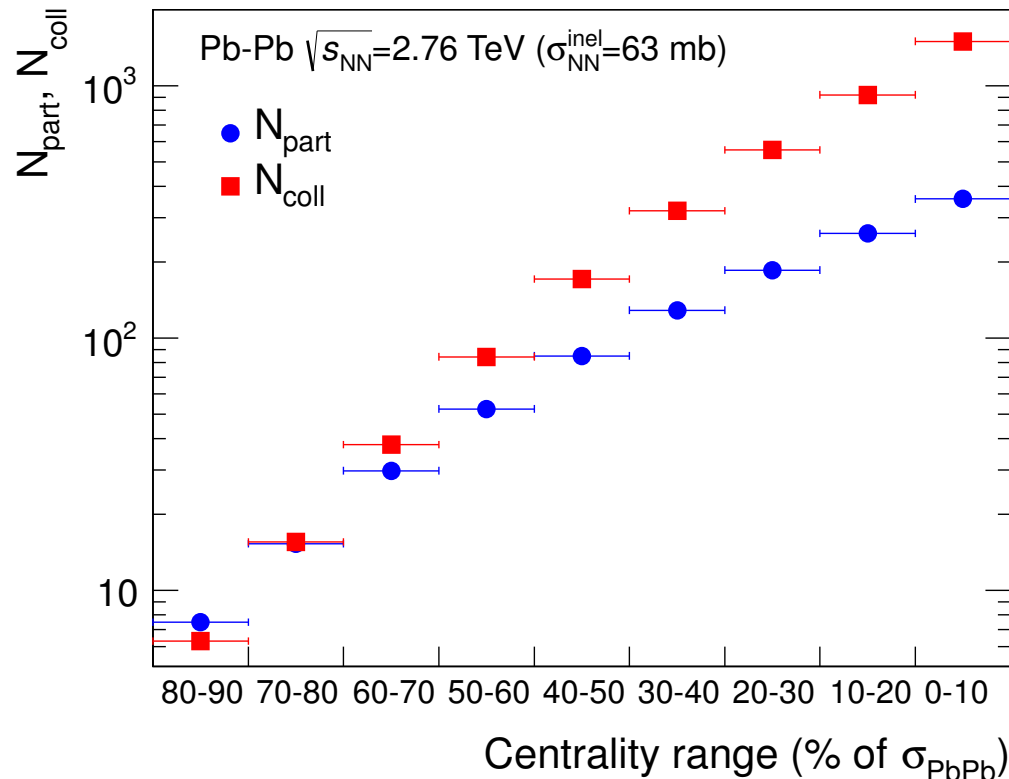

...while often taking as reference the measurement in proton-proton collisions (at the same energy), for "hard probes" (pQCD) scaled by the number of collisions corresponding to the given centrality class

# What we measure

Production yields and correlations as a function of kinematic quantities:

- transverse momentum,  $p_T = p \sin \theta$  (in GeV/c; recall:  $\beta = \frac{v}{c} = \frac{pc}{E}$ )

- rapidity,  $y = \frac{1}{2} \ln \frac{E+p_z}{E-p_z} = \tanh^{-1}(p_z/E)$ ;  $p_z = p_L = p \cos \theta$

additive for Lorentz transformations (equivalent of velocity for Galilei)

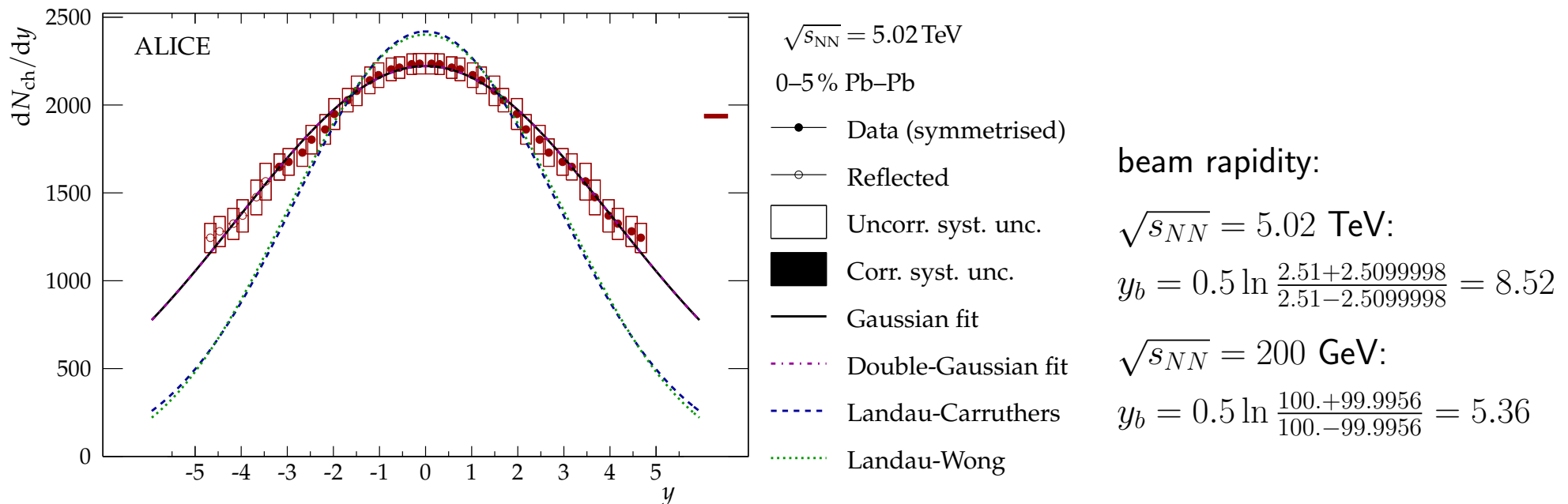

ALICE, [arXiv:1612.08966](https://arxiv.org/abs/1612.08966)

...poor (wo)man's  $y$ : "pseudorapidity",  $\eta = \tanh^{-1}(p_z/p) = \tanh^{-1}(\cos \theta)$

(without particle identification)

...  $\eta = y$  for  $m = 0$ ,  $\eta \simeq y$  for  $p \gg m$

# What we measure

We usually measure symmetric collisions of heavy nuclei (Au–Au, Pb–Pb) pp and p-Pb collisions as reference, but interesting on their own (limits of QGP)  
Need many collisions (millions), to sample properly the distributions

- Commonly charged particles, but neutral ones too (via their decays);  $\gamma$
- The amount of particles (count tracks, assembled from detector points)
- Momentum (via curvature in magnetic field) or energy (in a calorimeter)  
...or velocity (via a time-of-flight measurement, resolution 70 ps)
- Identify particles (via energy deposit in detector; ToF; invariant mass)
- Correlations between particles (in each event/collision)

Detector acceptance restricted around midrapidity ( $y, \eta = 0$ )

Single-particle detection efficiency: about 70-80%  
(from detailed Monte Carlo modelling of the detector)

# A pictorial summary of collisions at the LHC

A. Andronic

13

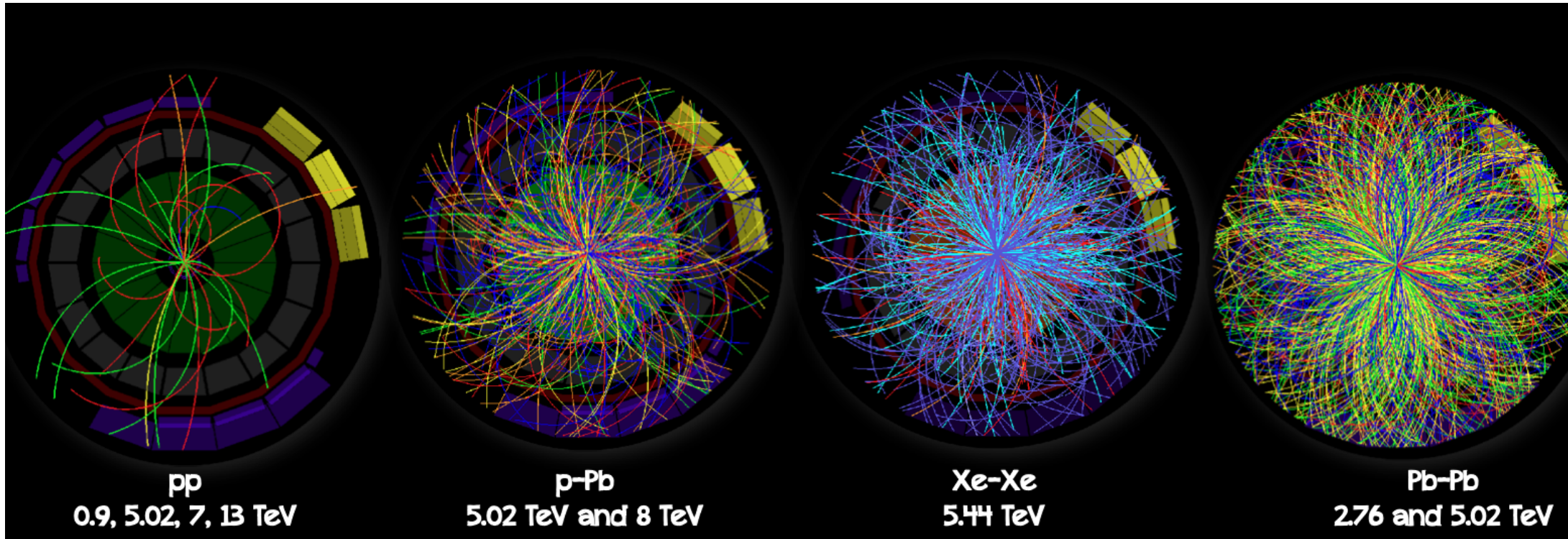

©C.Oppedisano/ALICE

# Nucleus-nucleus collisions at the LHC

A. Andronic

14

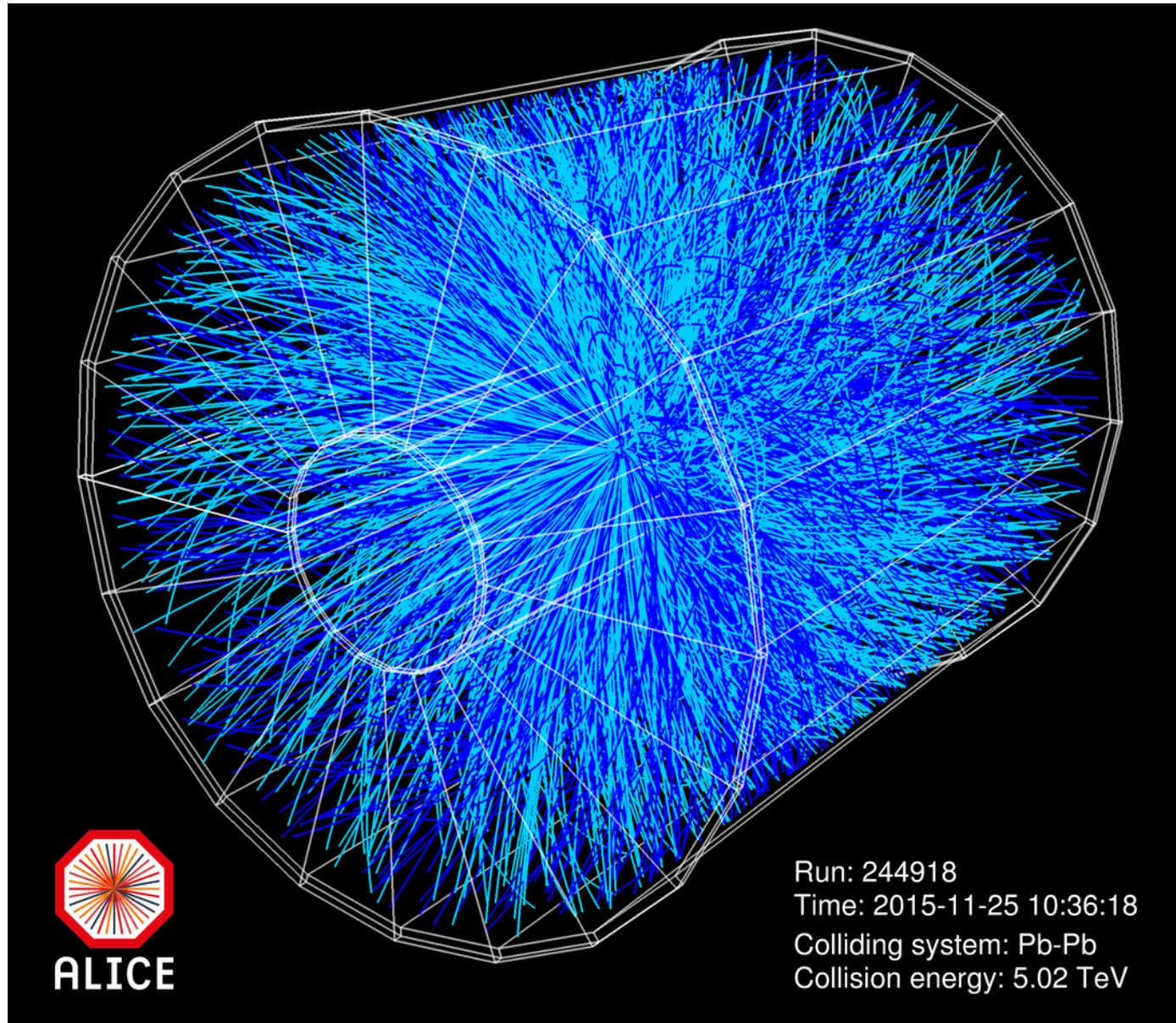

a picture of a central collision (about 3200 primary tracks in  $|\eta| < 0.9$ ); “Camera”: Time Projection Chamber  
5 m length, 5 m diam.; 500 mil. pixels; we take 50000 Pb-Pb “pictures” per second (fewer until 2021)

# Particle identification

A. Andronic

15

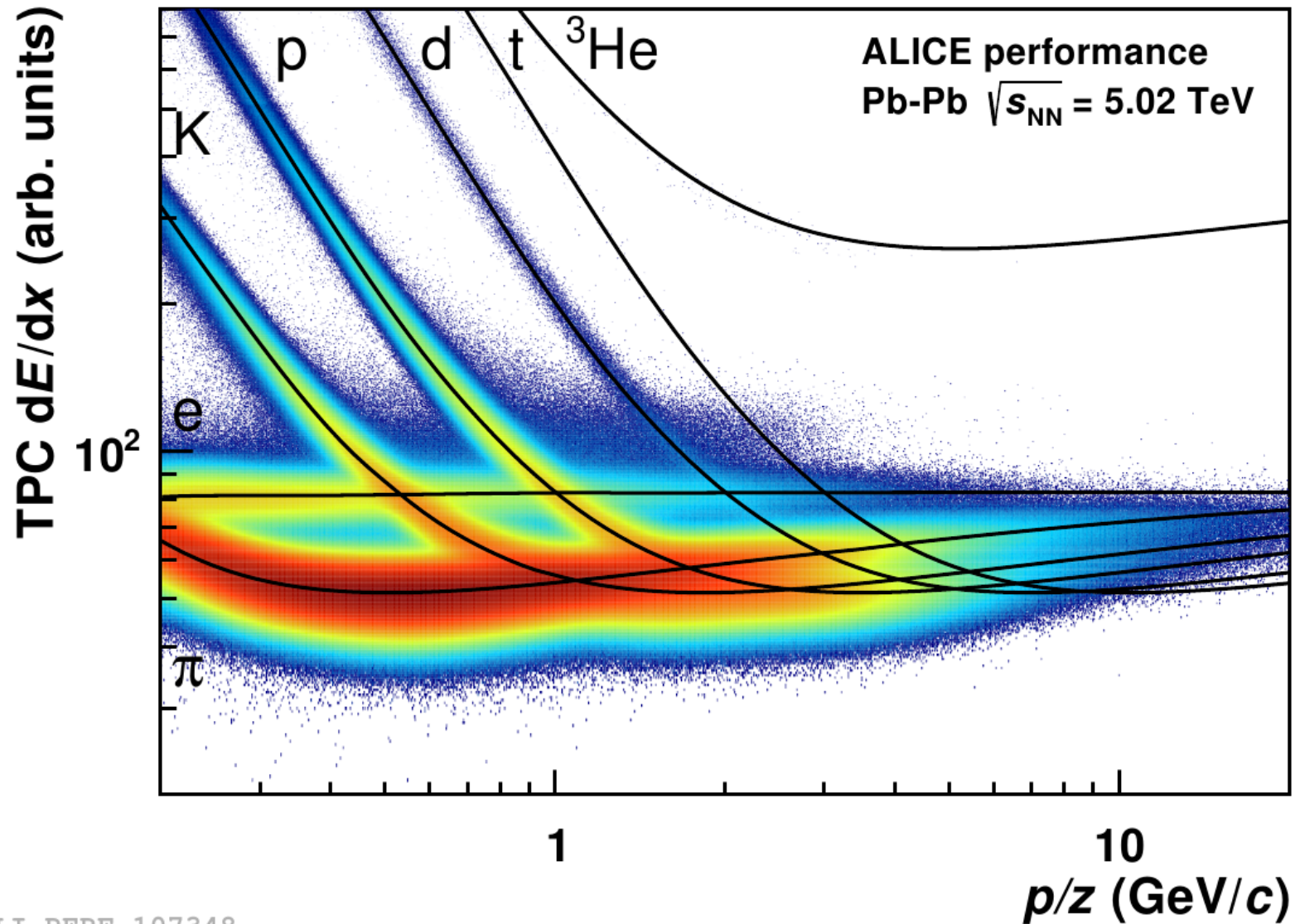

ALI-PERF-107348

$dE/dx$ : truncated mean of 159 samples along a track; resolution: 5.8%

lines: Bethe-Bloch parametrizations particles and antiparticles are shown

# Hadron yields (central collisions)

A. Andronic

16

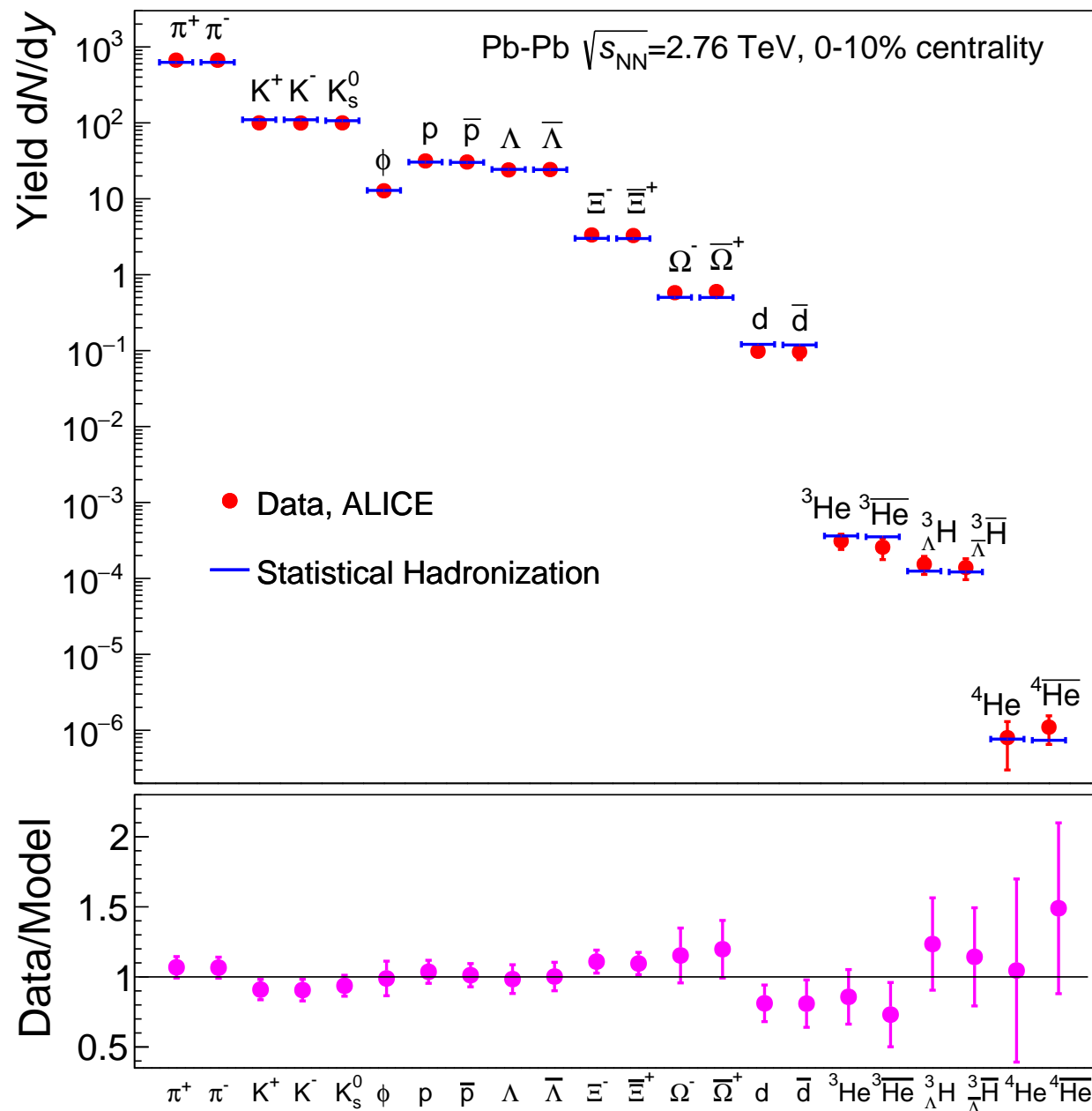

matter and antimatter produced  
in equal amounts at the LHC

*hadron abundances governed by  
chemical equilibrium*

best fit:

$$T_{CF} = 156.6 \pm 1.7 \text{ MeV}$$

$$\mu_B = 0.7 \pm 3.8 \text{ MeV}$$

$$V_{\Delta y=1} = 4175 \pm 380 \text{ fm}^3$$

$$(\chi^2/N_{df} = 16.7/19)$$

laboratory creation of a piece  
of hot Universe when  $10 \mu\text{s}$  old,  
 $T \simeq 10^{12} \text{ K}$



# Statistical hadronization (“thermal”) fits

$$n_i = N_i/V = -\frac{T}{V} \frac{\partial \ln Z_i}{\partial \mu} = \frac{g_i}{2\pi^2} \int_0^\infty \frac{p^2 dp}{\exp[(E_i - \mu_i)/T] \pm 1}$$

quantum nr. conservation ensured  
via chemical potentials:

$$\mu_i = \mu_B B_i + \mu_{I_3} I_{3i} + \mu_S S_i + \mu_C C_i$$

Latest PDG hadron mass spectrum  
(up to 3 GeV, 600 species)

Minimize:  $\chi^2 = \sum_i \frac{(N_i^{exp} - N_i^{therm})^2}{\sigma_i^2}$

$N_i$ : hadron yield  $\Rightarrow (T, \mu_B, V)$

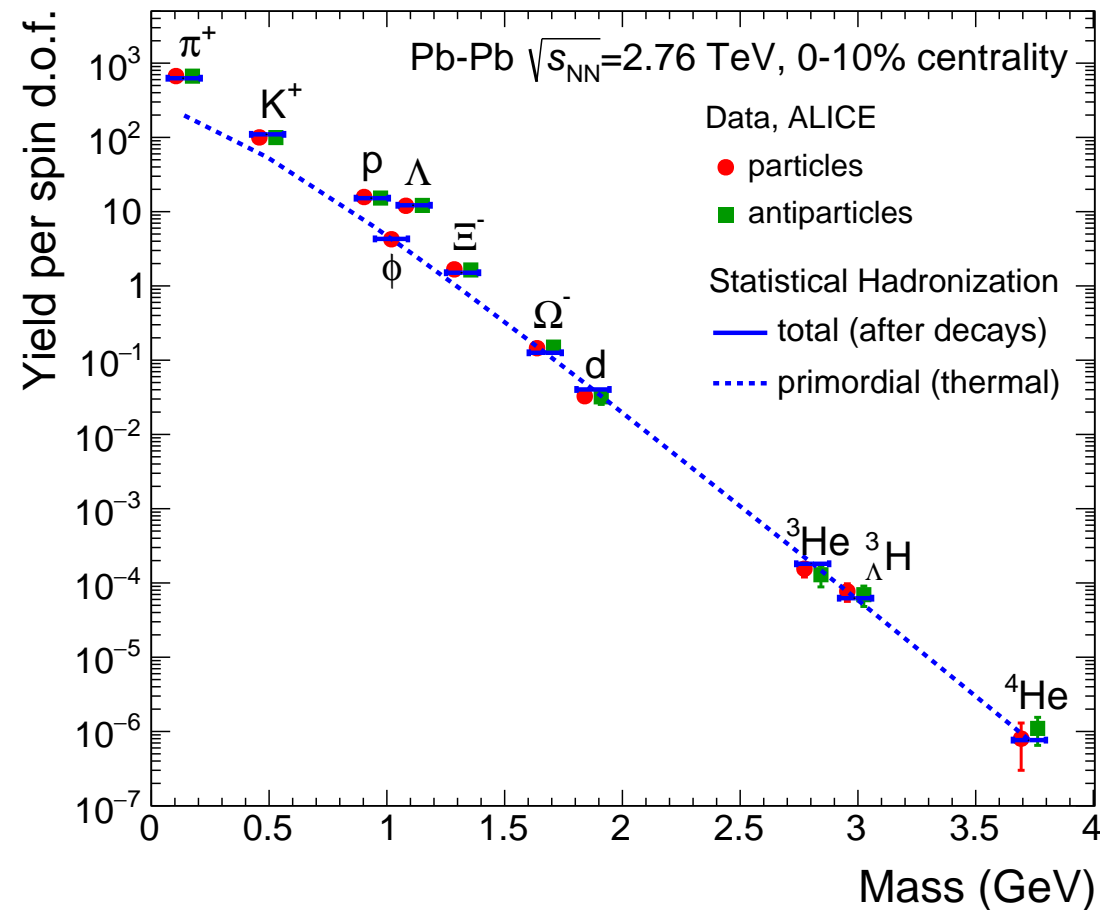

Strong (and EM, for  $\Lambda$ ) decays play a major role; approx.:  $\ln N \sim \ln(mT) - \frac{m}{T}$

Even loosely-bound objects ( $d, {}^3_\Lambda H$ ) seem produced at  $T=156$  MeV (?)

# The phase diagram of QCD

A. Andronic

18

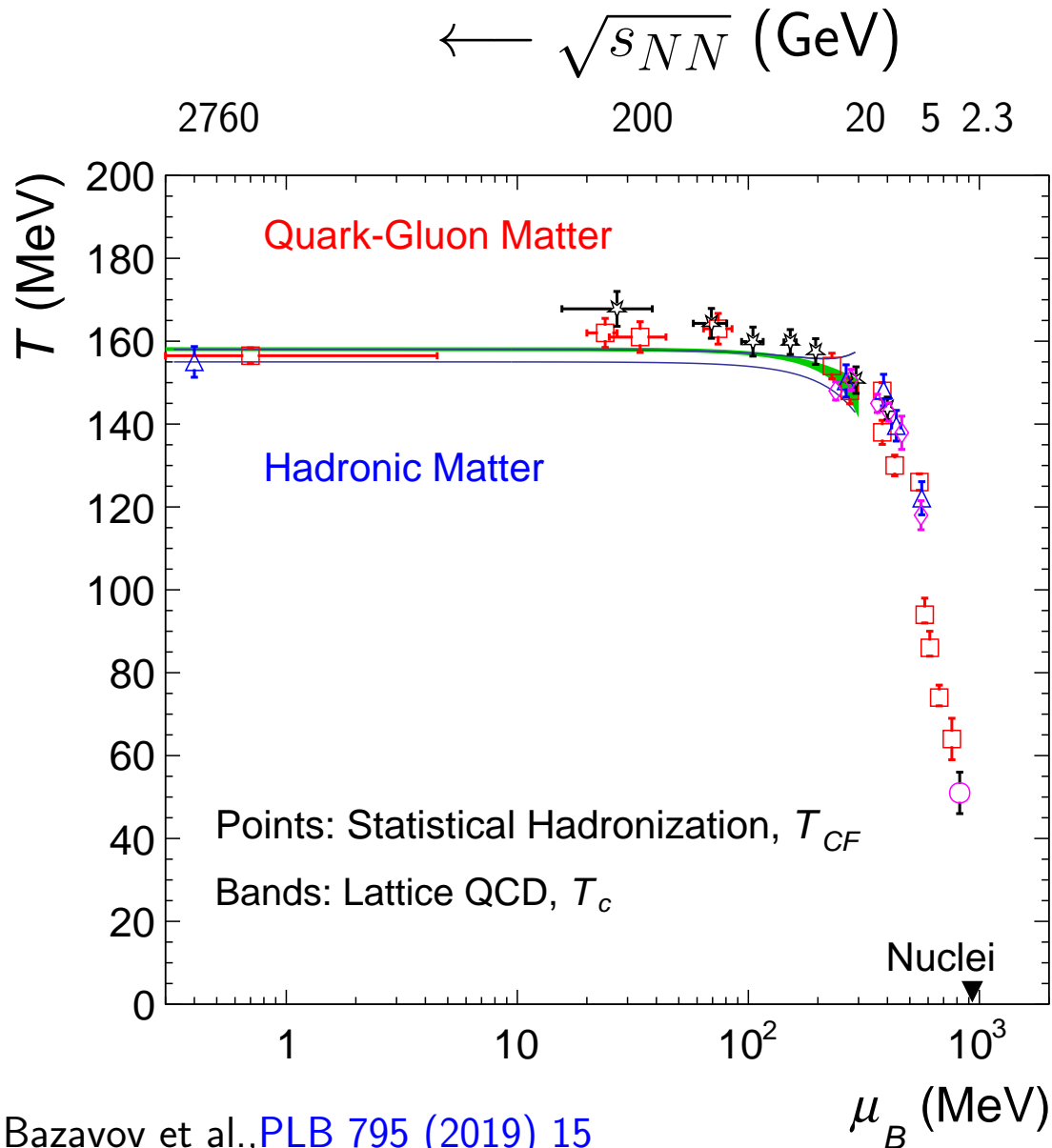

at LHC, remarkable “coincidence” with Lattice QCD phase crossover

at LHC ( $\mu_B \simeq 0$ ): purely-produced (anti)matter ( $m = E/c^2$ ), as in the Early Universe

$\mu_B > 0$ : more matter, from “remnants” of the colliding nuclei

$\mu_B \gtrsim 400$  MeV: *the critical point awaiting discovery (at FAIR?)*

Bazavov et al., [PLB 795 \(2019\) 15](#)

Borsanyi et al., [PRL 125 \(2020\) 052001](#)

Andronic et al., [Nature 561 \(2018\) 321](#)

$\mu_B$ : a measure of the net-baryon density, or matter-antimatter asymmetry

# The proton at low resolution ...in collisions at the LHC

A. Andronic

19

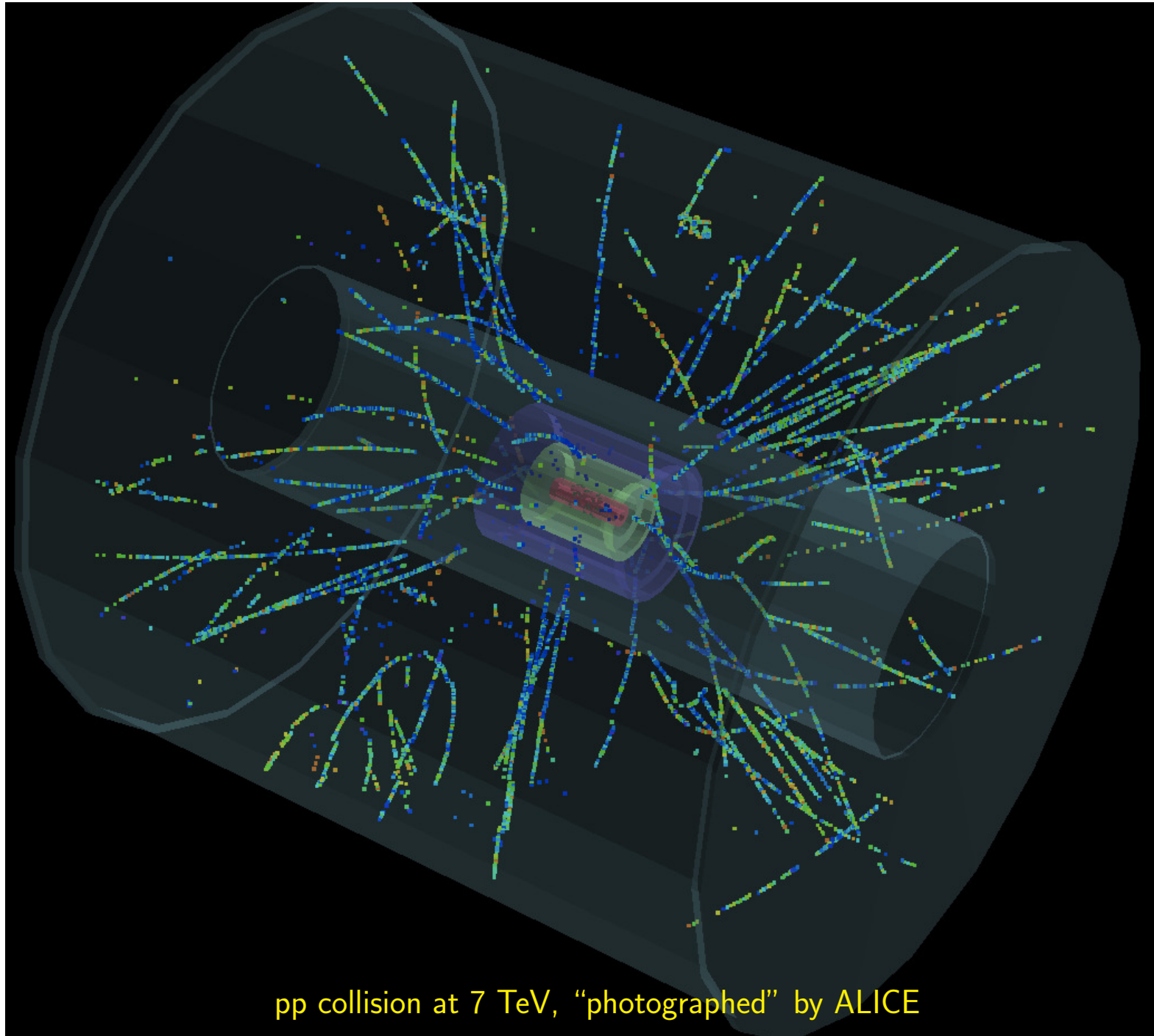

pp collision at 7 TeV, "photographed" by ALICE

# The proton at high resolution ...in collisions at the LHC

A. Andronic

20

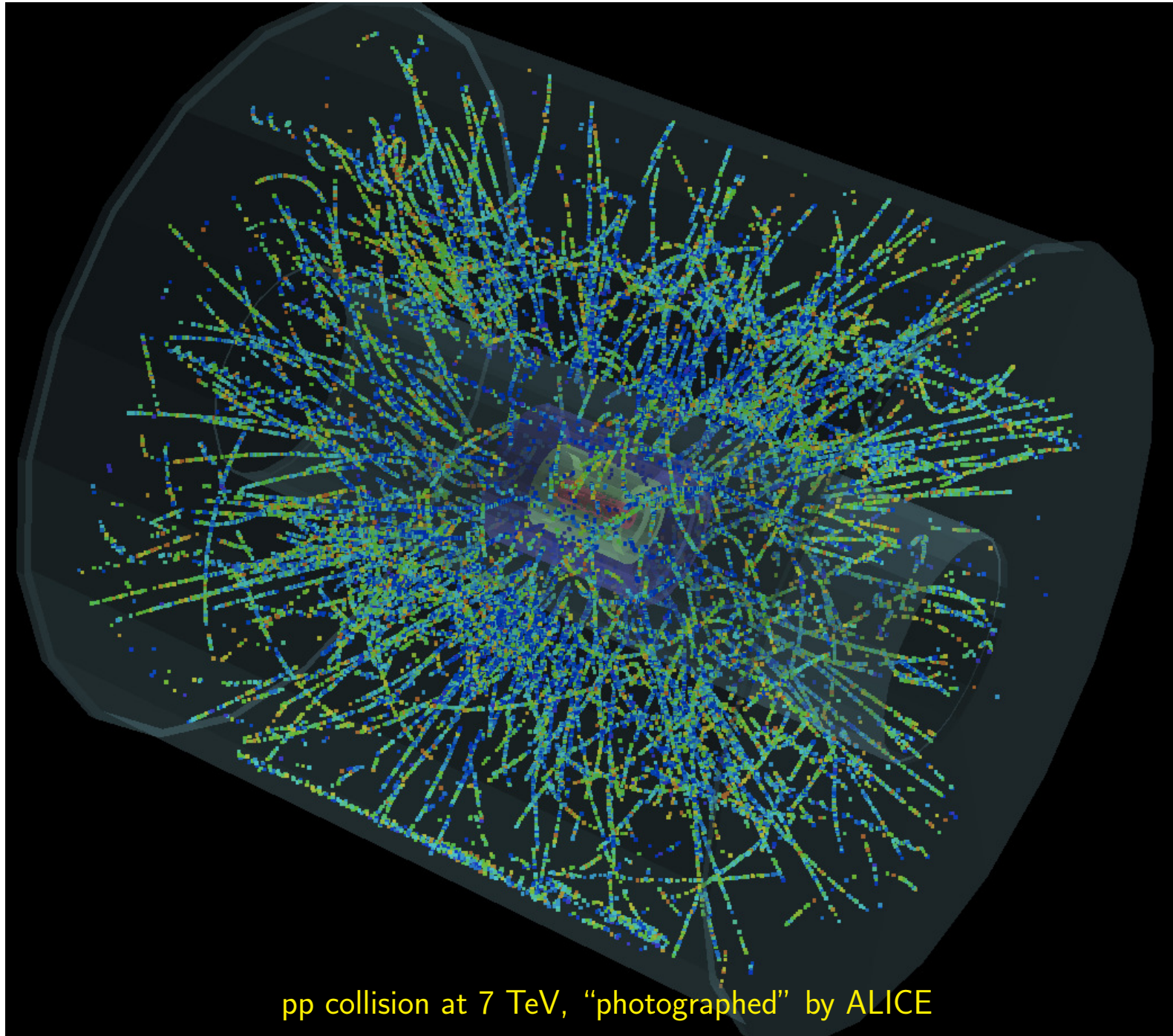

# Strangeness production - from small to large systems

A. Andronic

21

ALICE, [Nature Physics 13 \(2017\) 535](#)

(big geometric) fireball in Pb–Pb reached with violent pp and p–Pb collisions

canonical to grand-canonical strangeness production regime [Vislavicius, Kalweit, arXiv:1610.03001](#)

*is the same mechanism at work in small systems (at large multiplicities)?*

string hadronization (PYTHIA8) does not describe data

DIPSY (Mueller's dipole, BFKL evolution) fares better Dipole evolution in Impact Parameter Space and rapidity

[Flensburg, Gustafson, Lonnblad, arXiv:1103.4321](#)

EPOS LHC: core(QGP)-corona model

new ideas: ropes; thermodynamical string fragmentation

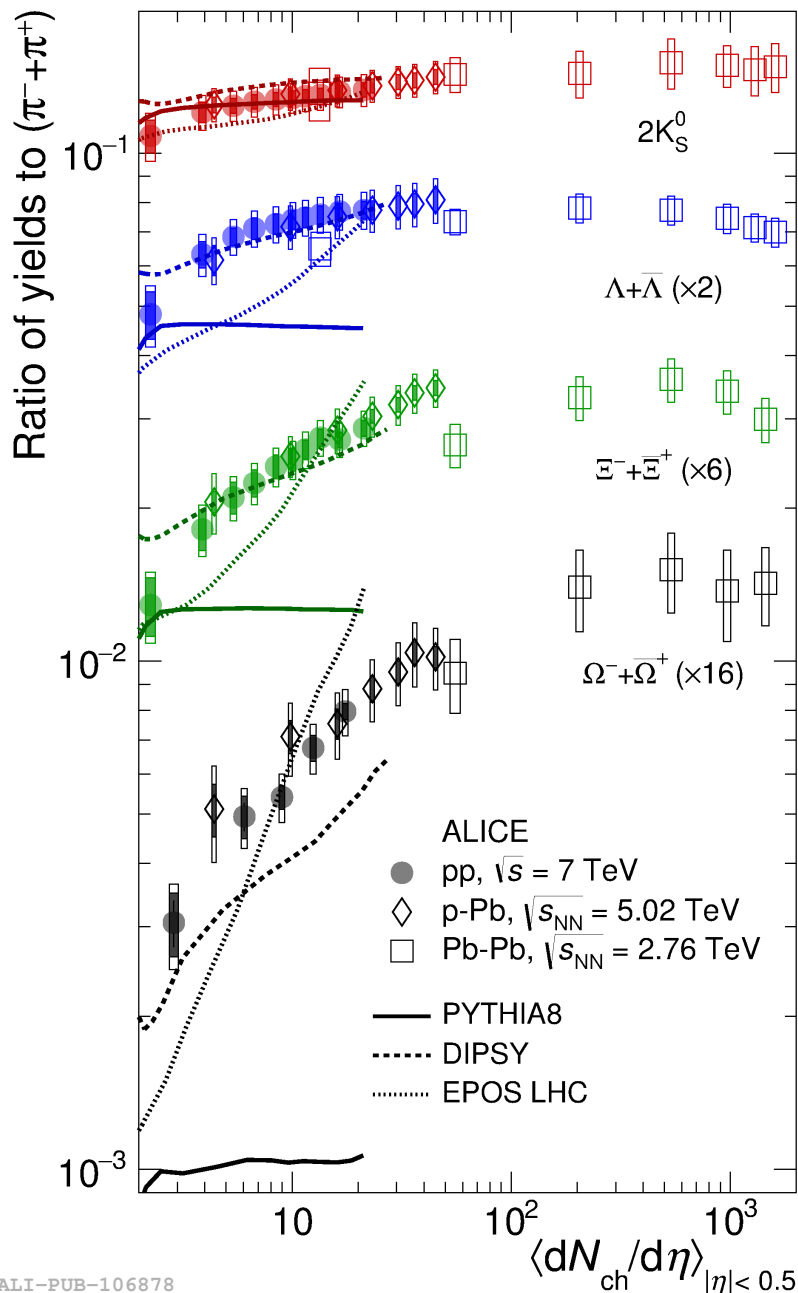

# Elliptic flow

A. Andronic

22

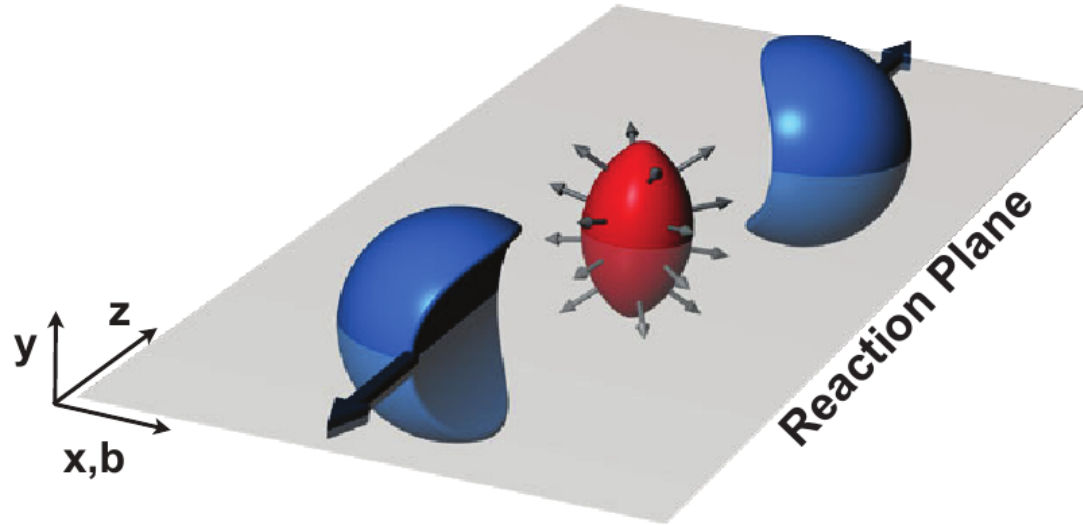

$$\frac{dN}{d\varphi} \sim [1 + 2v_1 \cdot \cos(\varphi) + 2v_2 \cdot \cos(2\varphi) + \dots]$$

$\varphi$  = azimuthal angle with respect to reaction plane

$v_2 = \langle \cos(2\varphi) \rangle$  we call *elliptic flow*

R. Snellings, [arXiv:1102.3010](https://arxiv.org/abs/1102.3010)

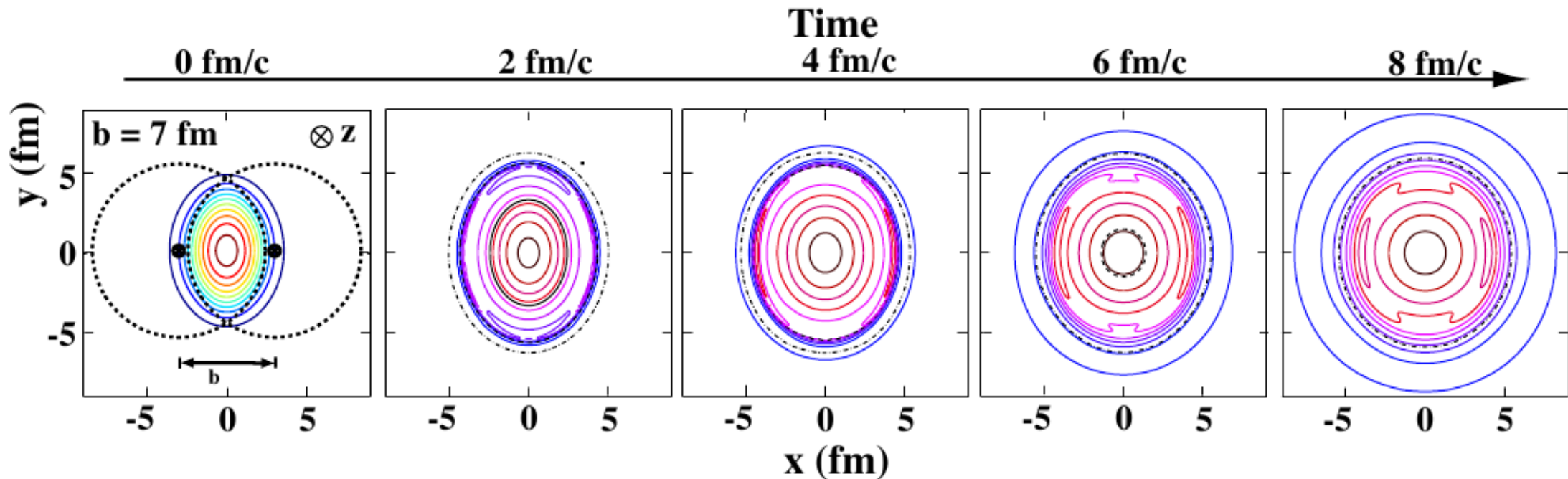

# Flow harmonics: all collision systems

A. Andronic

23

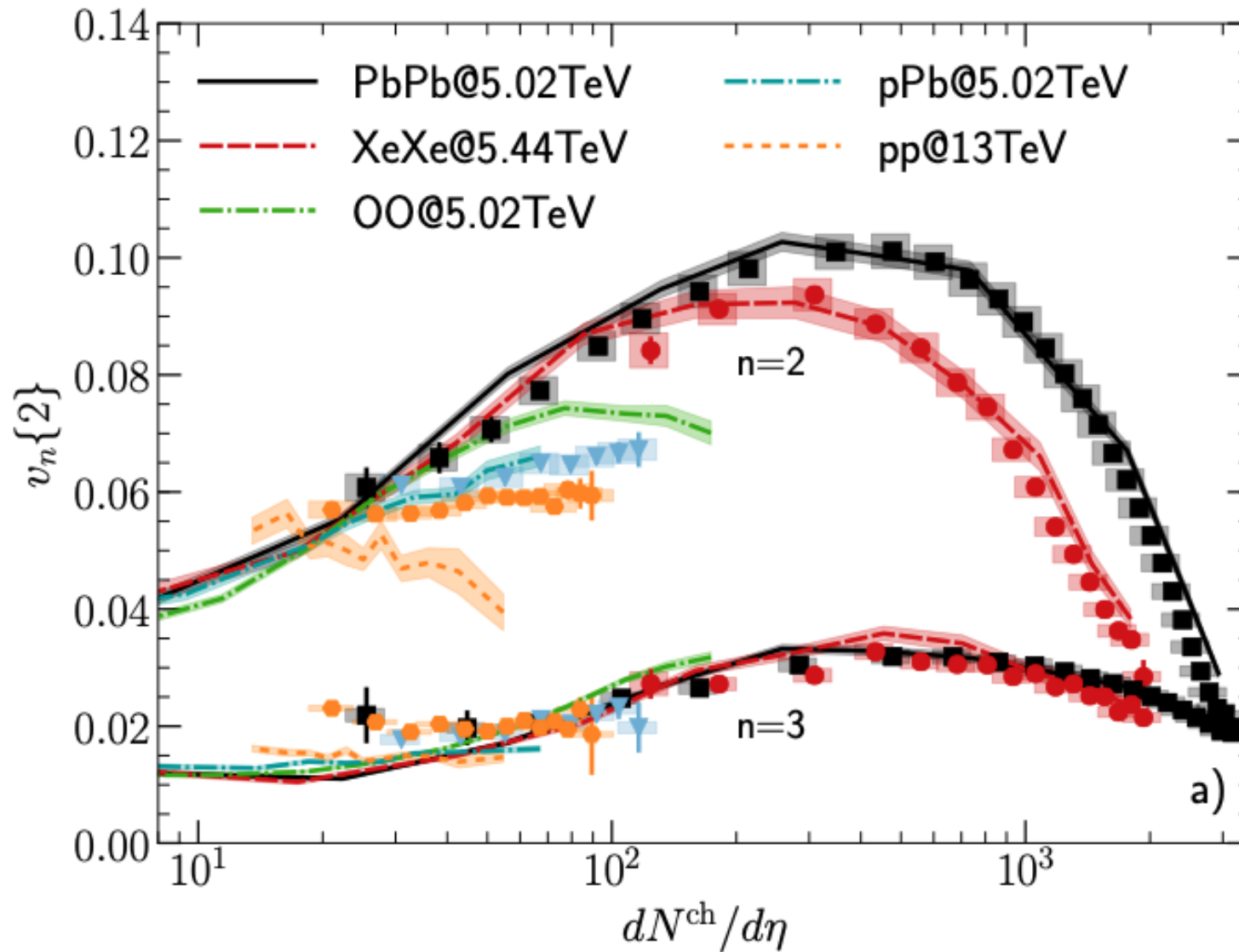

Symbols: data, ALICE, [PRL 123 \(2019\) 142301](#)

Lines: hydrodynamics, Schenke, Shen, Tribedy [PRC 102 \(2020\) 044905](#)

# Thermodynamic quantities: data-hydrodynamics

A. Andronic

24

Data: effective values  
(average over time)  
processed through  
hydrodynamics

Effective number of  
degrees of freedom:  
 $g \simeq 30$  ( $\gg 3$ , pions)

ideal gas of quarks  
and gluons:  $g=52$

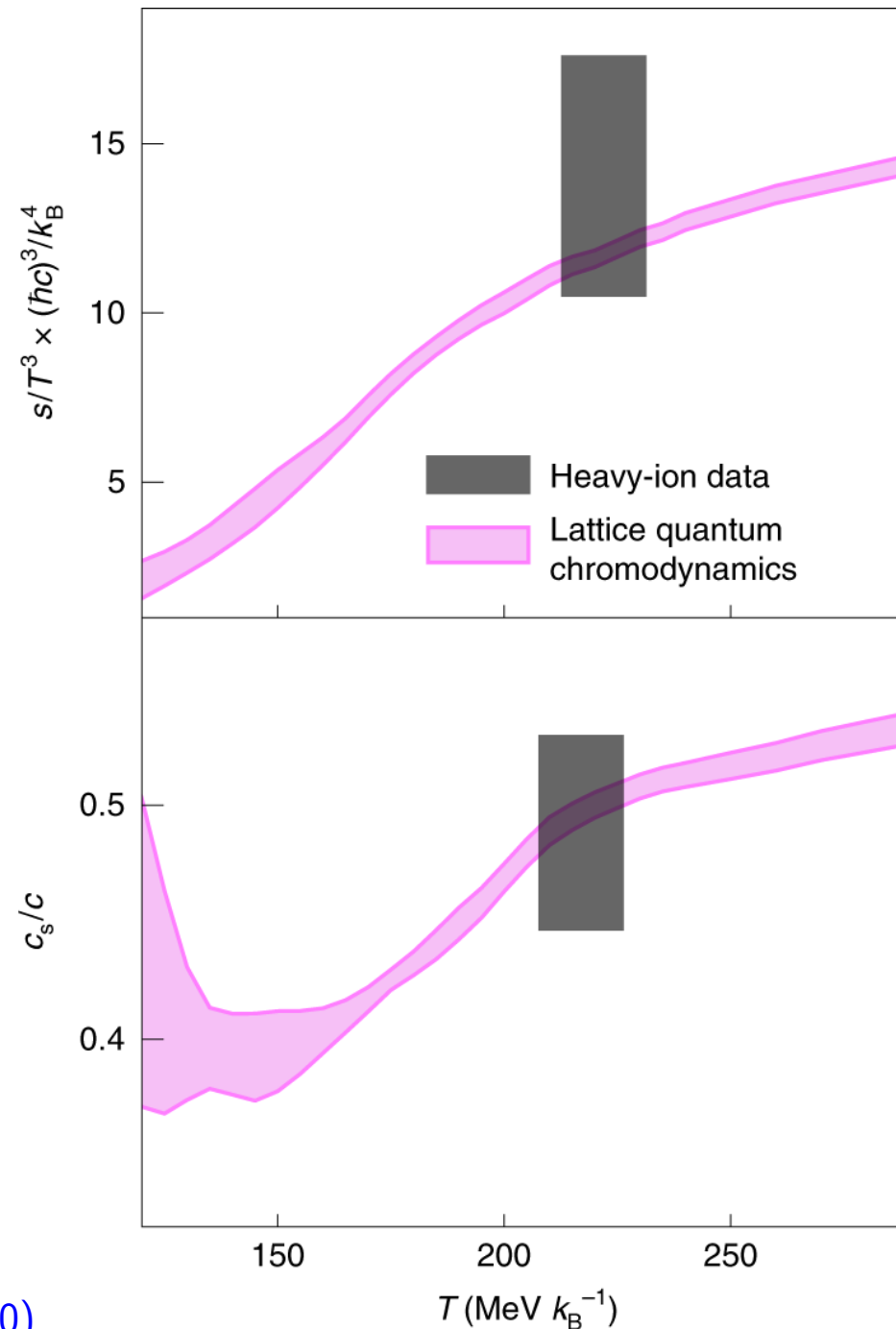



# Good fluids (ratio viscosity / entropy density)

A. Andronic

25

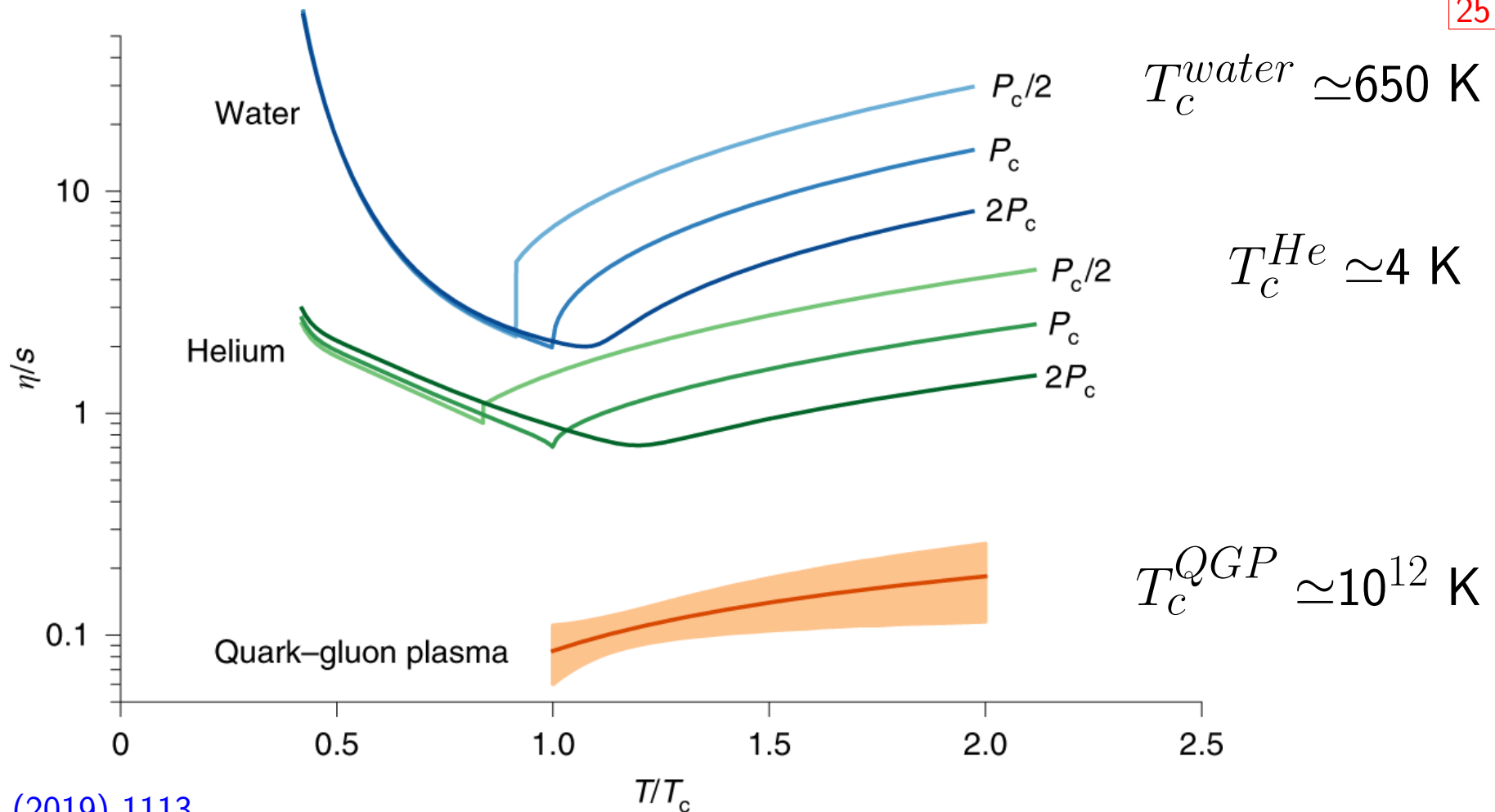

Bernhard, et al.,

Nature Physics 15 (2019) 1113

Dilute gas:  $\eta = \frac{1}{3}n\langle p \rangle \lambda$ ;  $\lambda \sim \frac{1}{n} \rightarrow \eta$  indep. on  $n$

Lowest value of  $1/4\pi$  predicted by gravity-gauge duality (AdS-CFT) conjecture

"Simple-minded":  $\eta/s \simeq \eta/(k_B n) = p\lambda/3k_B \gtrsim \hbar/3k_B$  ( $\Delta p \cdot \Delta x \geq \hbar$ )

# Flow harmonics

$v_2$  (elliptic flow) is the dominant flow harmonics, except for most central collisions

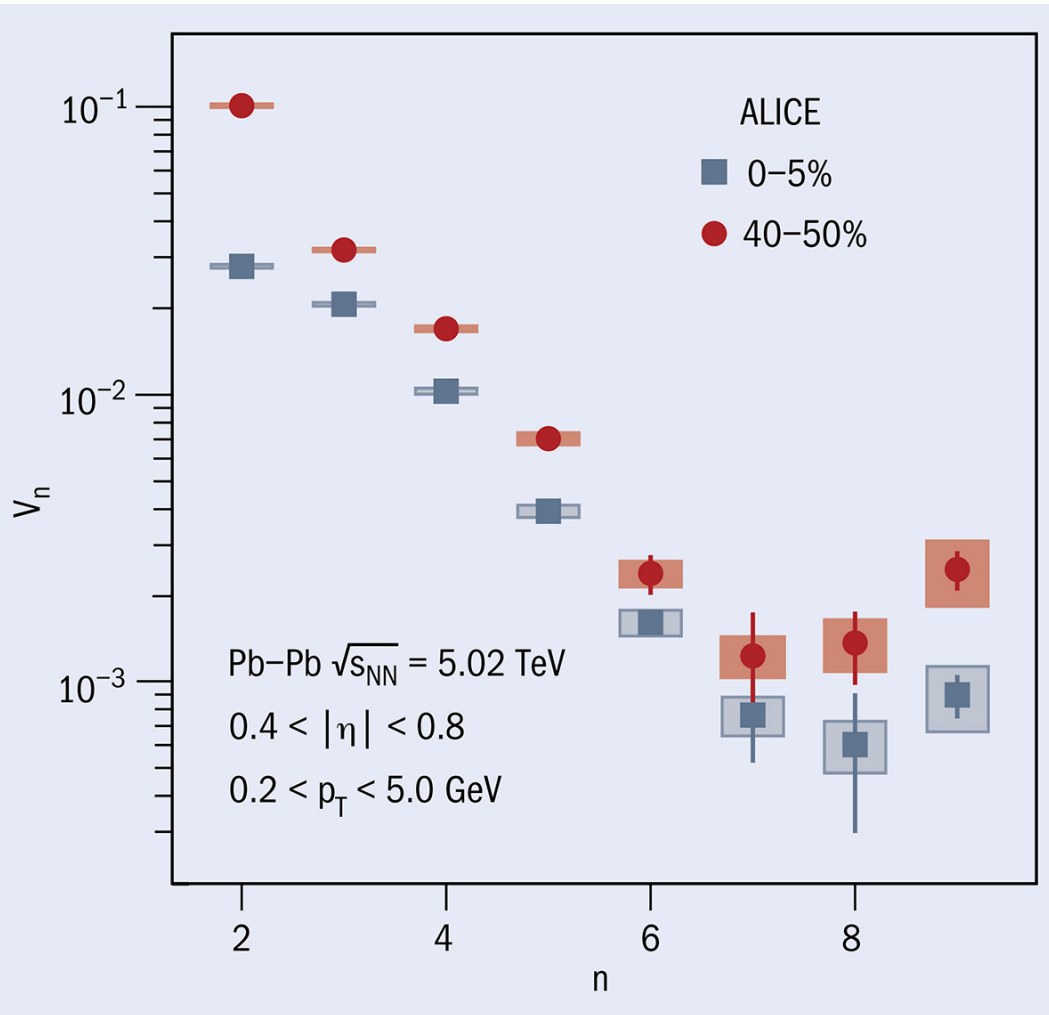

Analogy?

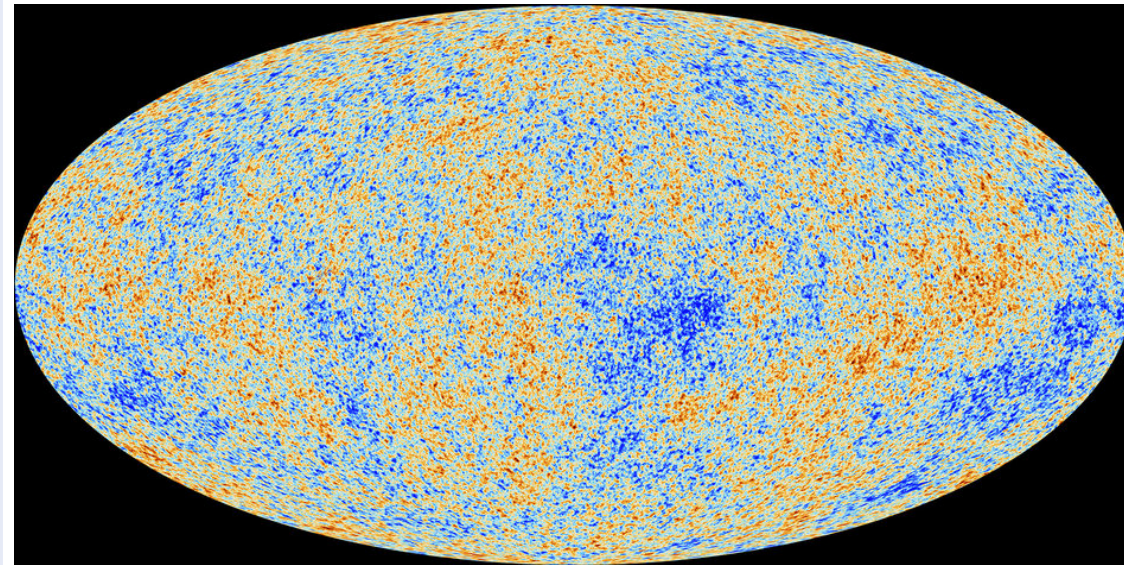

[http://www.esa.int/Our\\_Activities/Space\\_Science/Planck](http://www.esa.int/Our_Activities/Space_Science/Planck)

the non-uniformities ( $10^{-5}$ ) are the seeds of the  $\sim 100$  billion of seen galaxies

Dominant multipole  $l \simeq 100$  (angular scale:  $1^\circ$ )

# The initial femtosopic (gluonic) state

A. Andronic

27

central Pb–Pb collision,  $\sqrt{s_{NN}}=5.02$  TeV ( $R_{Pb}=6.62$  fm)

theoretical calculation (Color Glass Condensate)

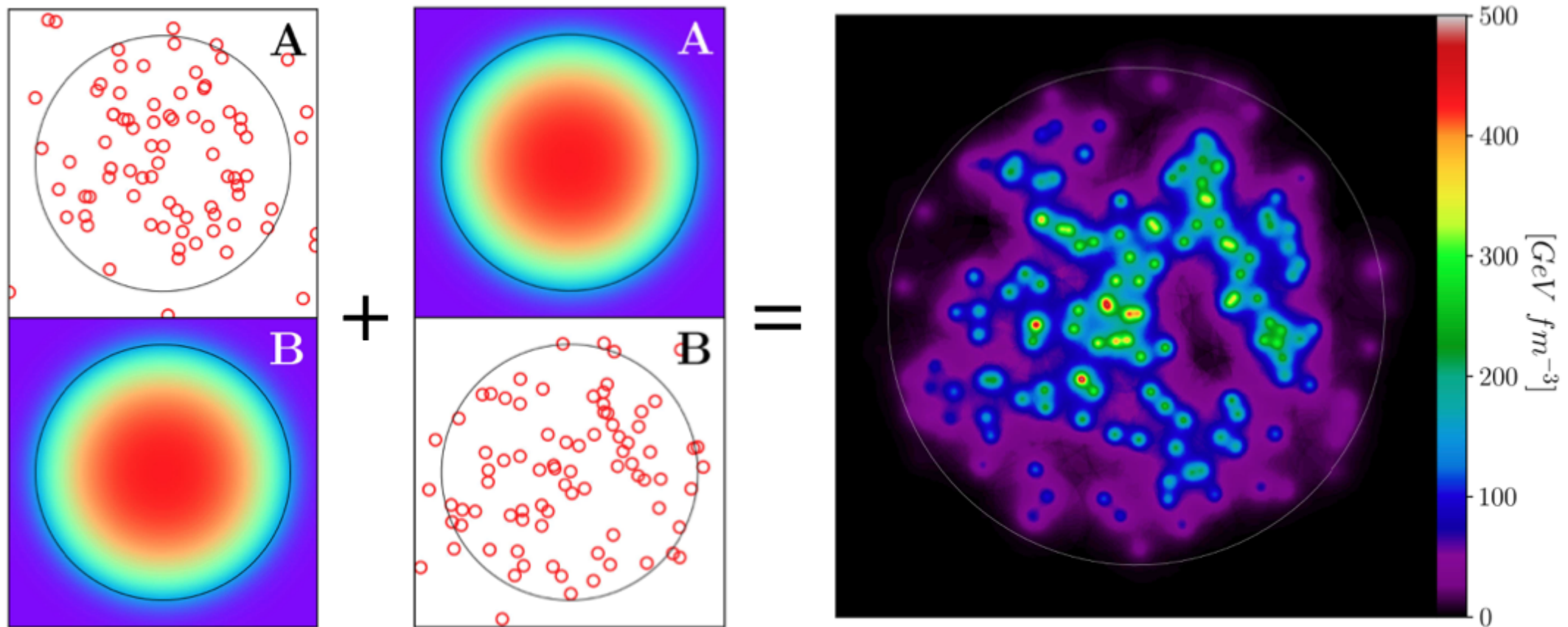

Gelis et al, [arXiv:1907.10948](https://arxiv.org/abs/1907.10948)

Mean energy density at the center:  $131 \text{ GeV}/\text{fm}^3$  ( $\alpha_s=0.25$ )

# Probing early stages

...with "hard probes" ( $m \gg T$ ): jets or high- $p_T$  hadrons (or heavy quarks)

produced very early in the collision,  $t \simeq 1/m$

(jets - sprays of hadrons from high-speed quarks)

- $q, \bar{q}, g$  travel through QGP, lose energy
- hadronize (neutralize color picking up partners from the vacuum)
- hadrons fly towards detectors

...where we observe a deficit at high momenta ( $p_T$ ): "jet quenching"  
(Bjorken, 1982)

quantified by the nuclear modification factor:

$$R_{AA} = \frac{dN_{AA}/dp_T dy}{N_{coll} \cdot dN_{pp}/dp_T dy}$$

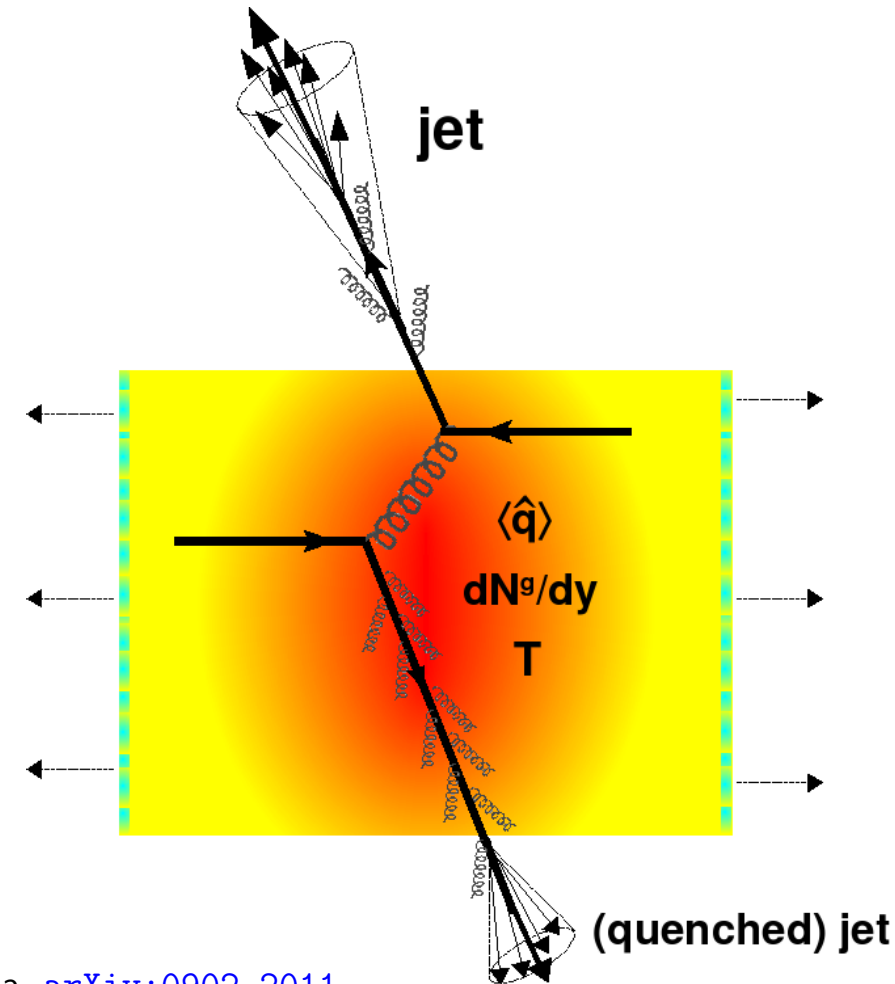

# Jets in Pb–Pb collisions

A. Andronic

29

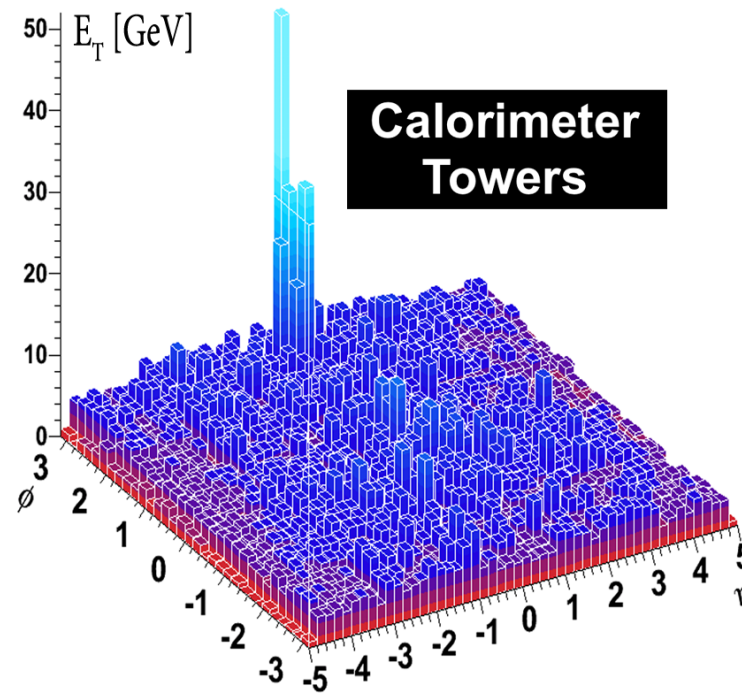
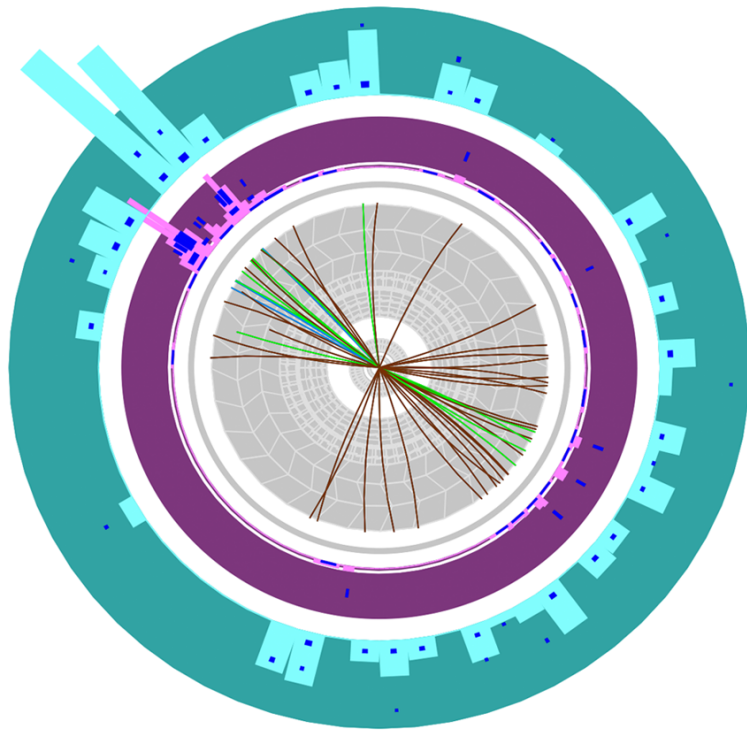

## ATLAS

Run: 169045  
Event: 1914004  
Date: 2010-11-12  
Time: 04:11:44 CET

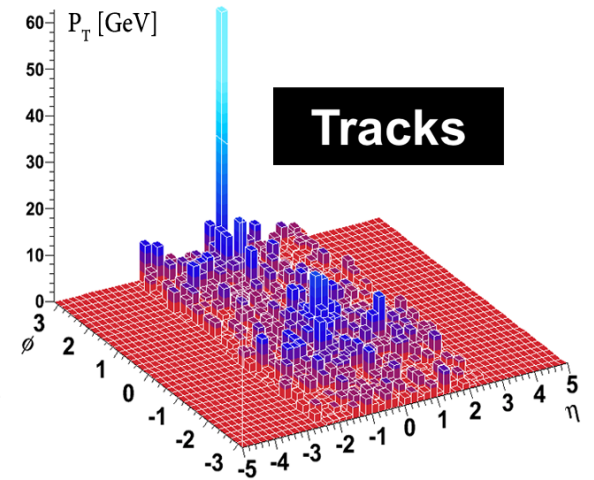

first “direct” observation of “disappearance” of a jet ( $E_T > 100$  GeV) in AA

tracks with  $p_T > 2.6$  GeV; calorimeter cell thresholds:  $E_T > 0.7$  GeV ECAL,  $E > 1$  GeV HCAL

quantitatively:

(“leading jet”)  $E_{T1} > 100$  GeV vs. the highest  $E_T$  jet in the opposite hemisphere,  $E_{T2} > 25$  GeV

$E_T$  after subtracting the average contribution of the **underlying event** ( $\simeq 75$  GeV for central coll.)

ATLAS, [PRL 105 \(2010\) 252303](#)

...in vacuum

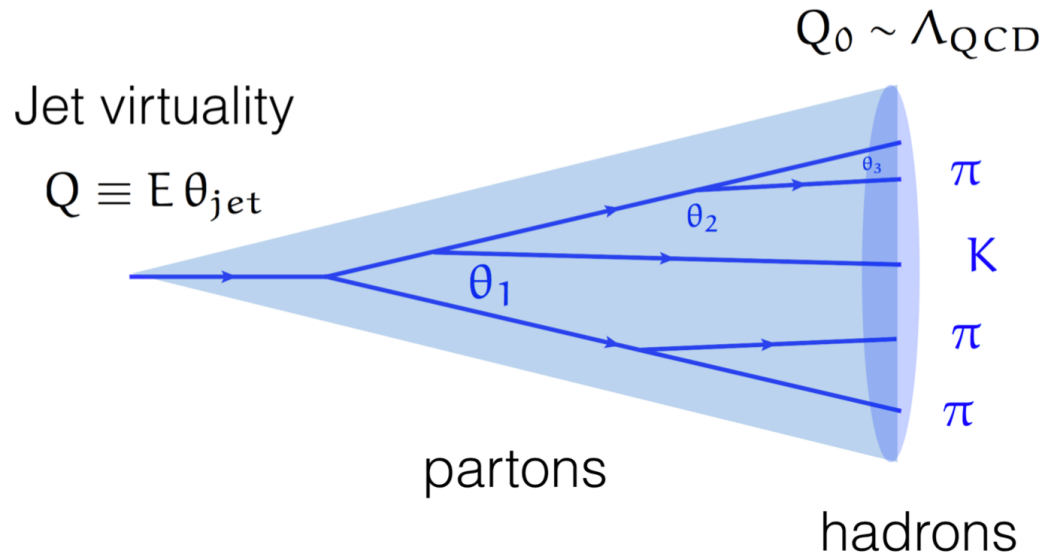

...in medium

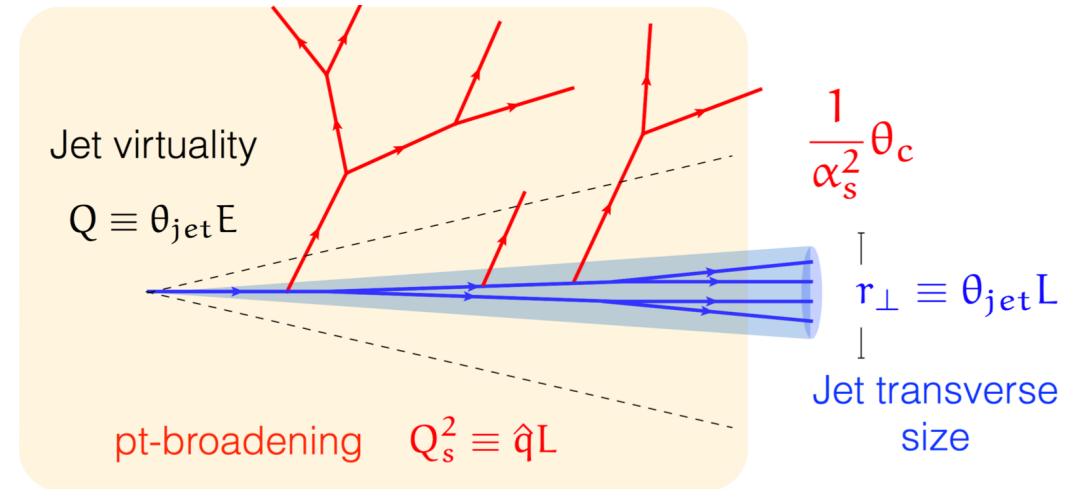

$E$ :  $E_T$  or  $p_T$ ;  $\theta_{jet}$ : opening angle ( $R$  or  $\Delta R$ )

Is this (theoretical expectation) a quantitative effect of the medium?

# Jet fragmentation function

Fraction of jet (parton)  $p_T$  carried by constituent hadrons

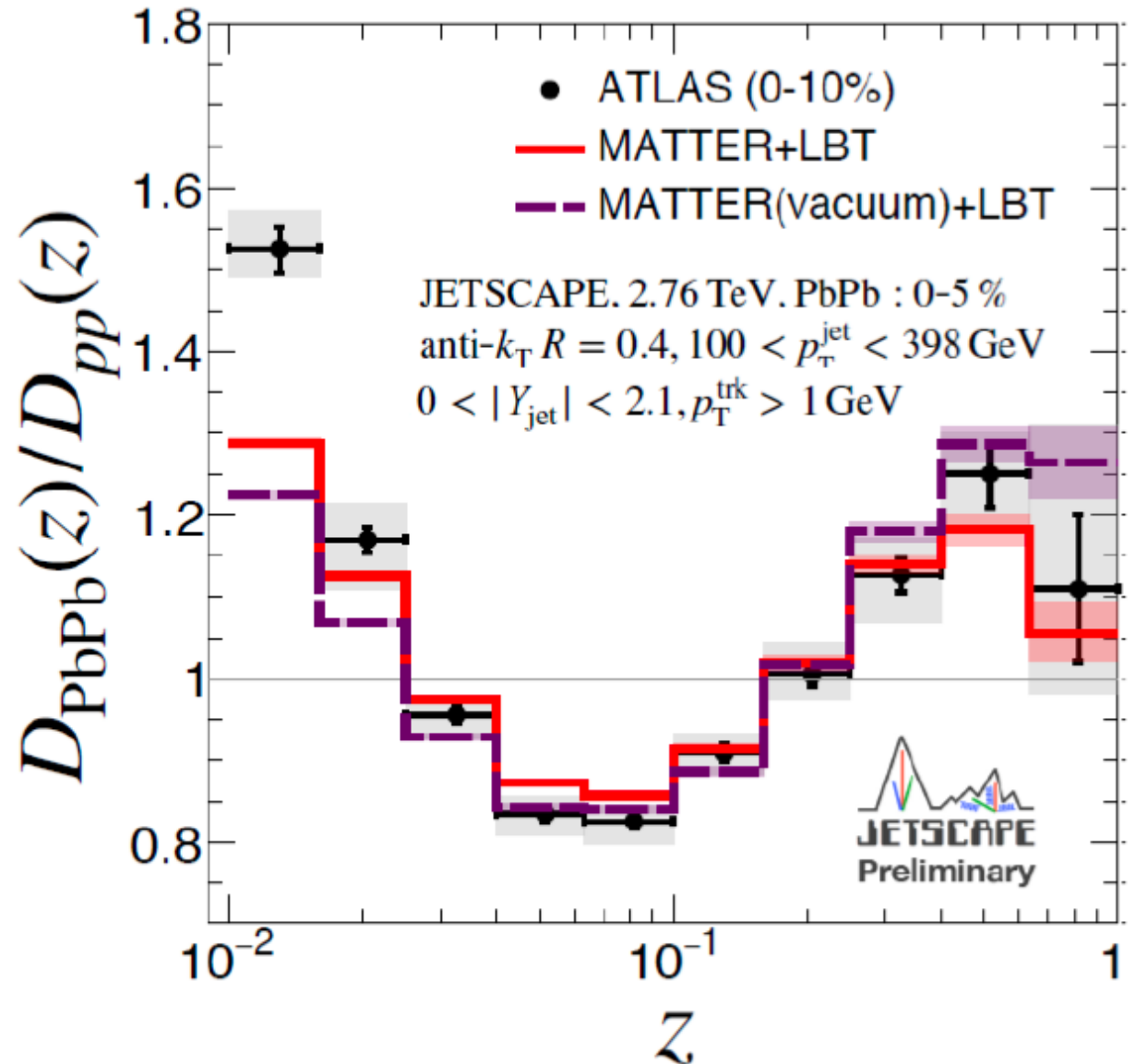
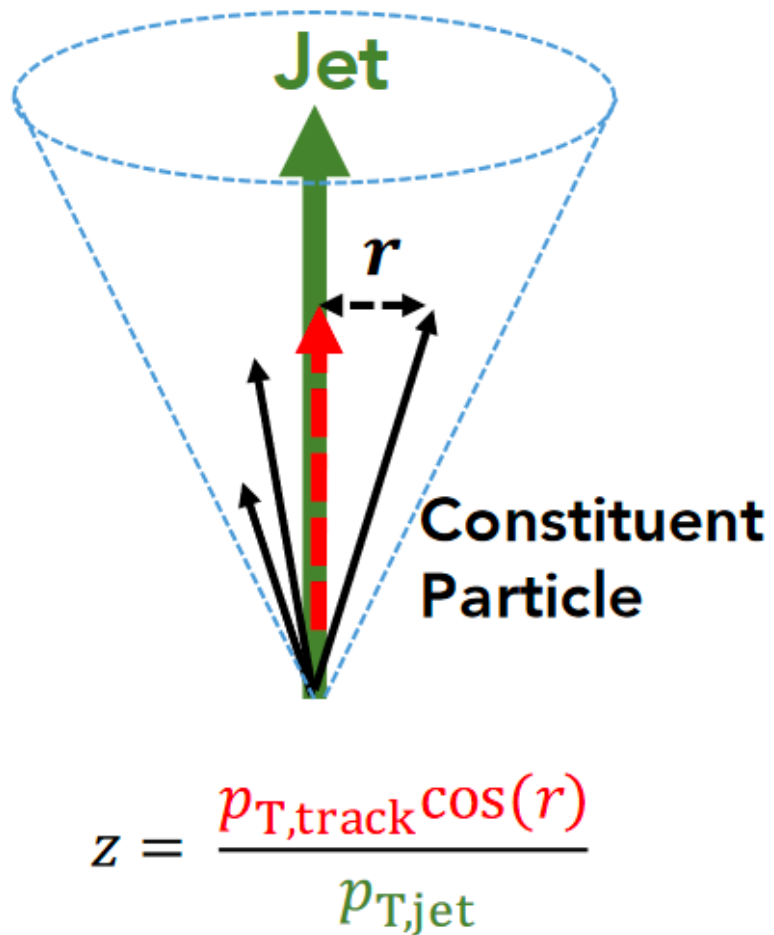

Significantly modified in Pb-Pb (more high- and low- $p_T$  constituents)

# Parton energy loss in the medium ( $T$ )

## Collisional

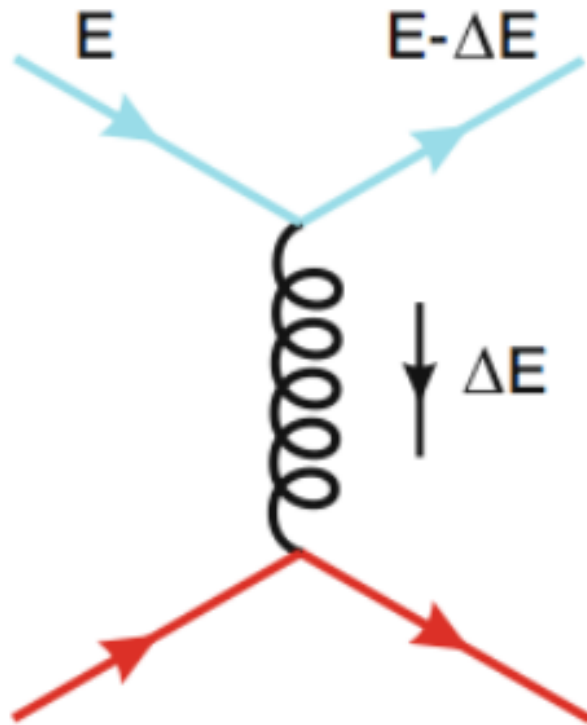

Important at low momenta

$$\Delta E \sim L, T^3$$

## Radiative

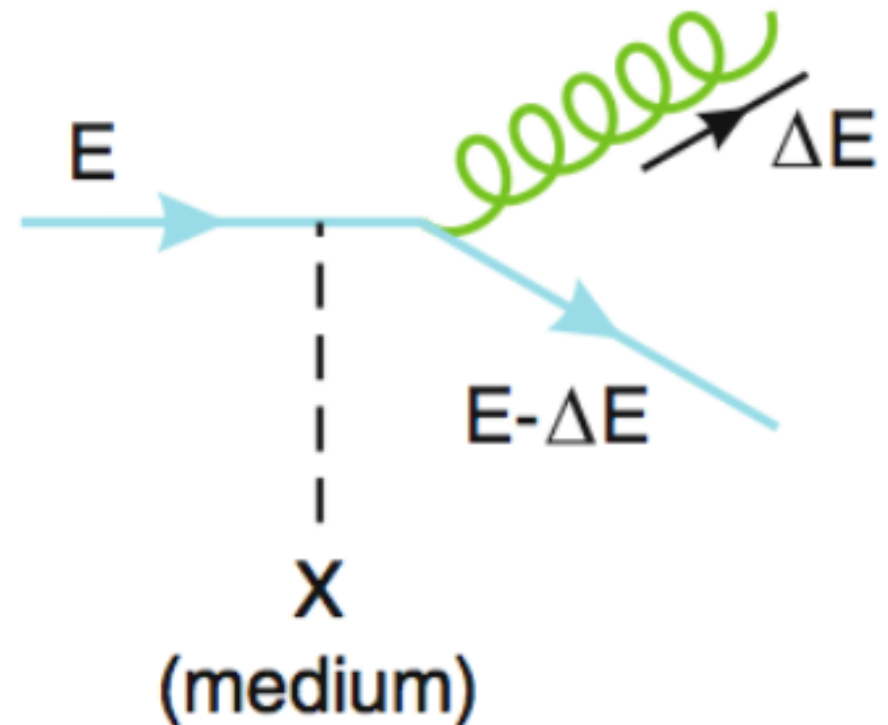

Important at high momenta

$$\Delta E \sim L^2, T^3$$

For energetic partons radiative energy loss dominates,  $\Delta E_{rad} \sim \alpha_s \hat{q}$



# Jet quenching at the LHC - leading hadrons

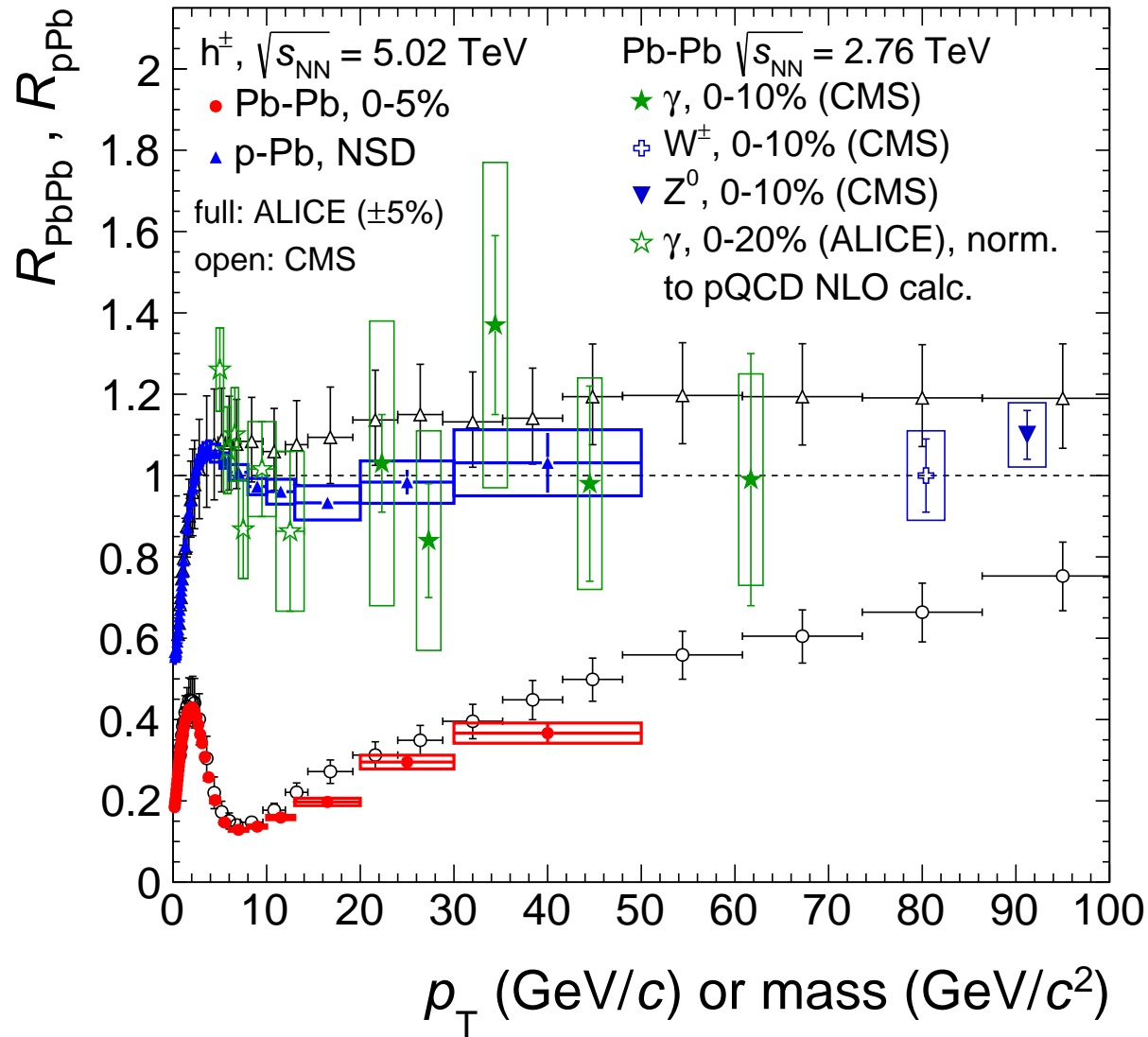

measured with "leading hadrons"  
strong suppression, reaching a factor of about 7,  $p_T \simeq 7 \text{ GeV}/c$   
remains substantial even at 50-100  $\text{GeV}/c$

not seen with EW observables ( $\gamma, W^\pm, Z^0$ ) ...ALICE  $\gamma / pQCD \text{ NLO calc.}$

not seen in p-Pb collisions ( $p_T \lesssim 3 \text{ GeV}/c$ , gluon saturation)

ALICE, [JHEP 1811 \(2018\) 013](#)

a thermal component,  $p_T \lesssim 6 \text{ GeV}/c$  (scaling with  $N_{part}$ ) determined by gluon saturation and collective flow

# Jet quenching: transport coefficient

...extracted from a global fit of data

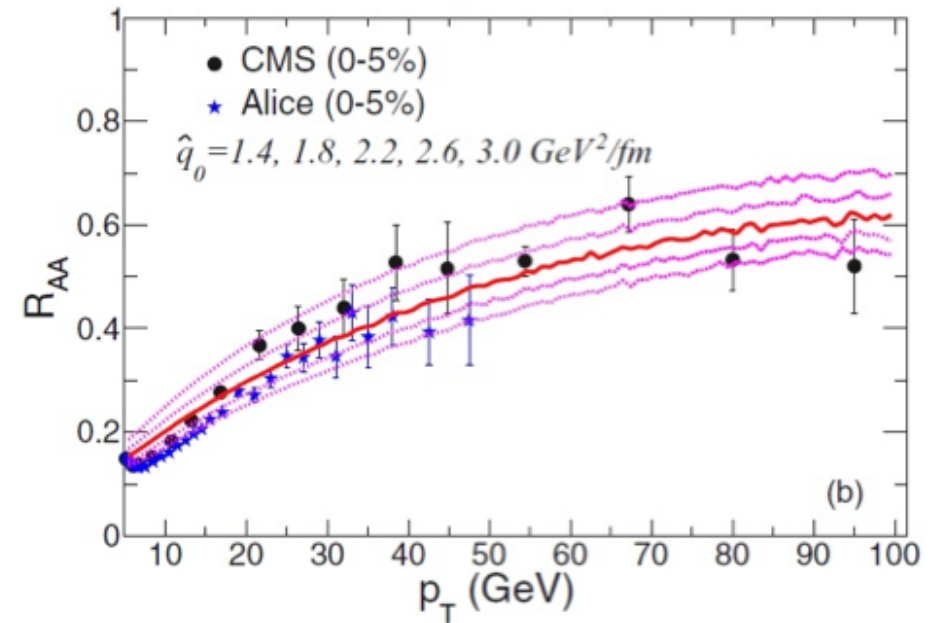
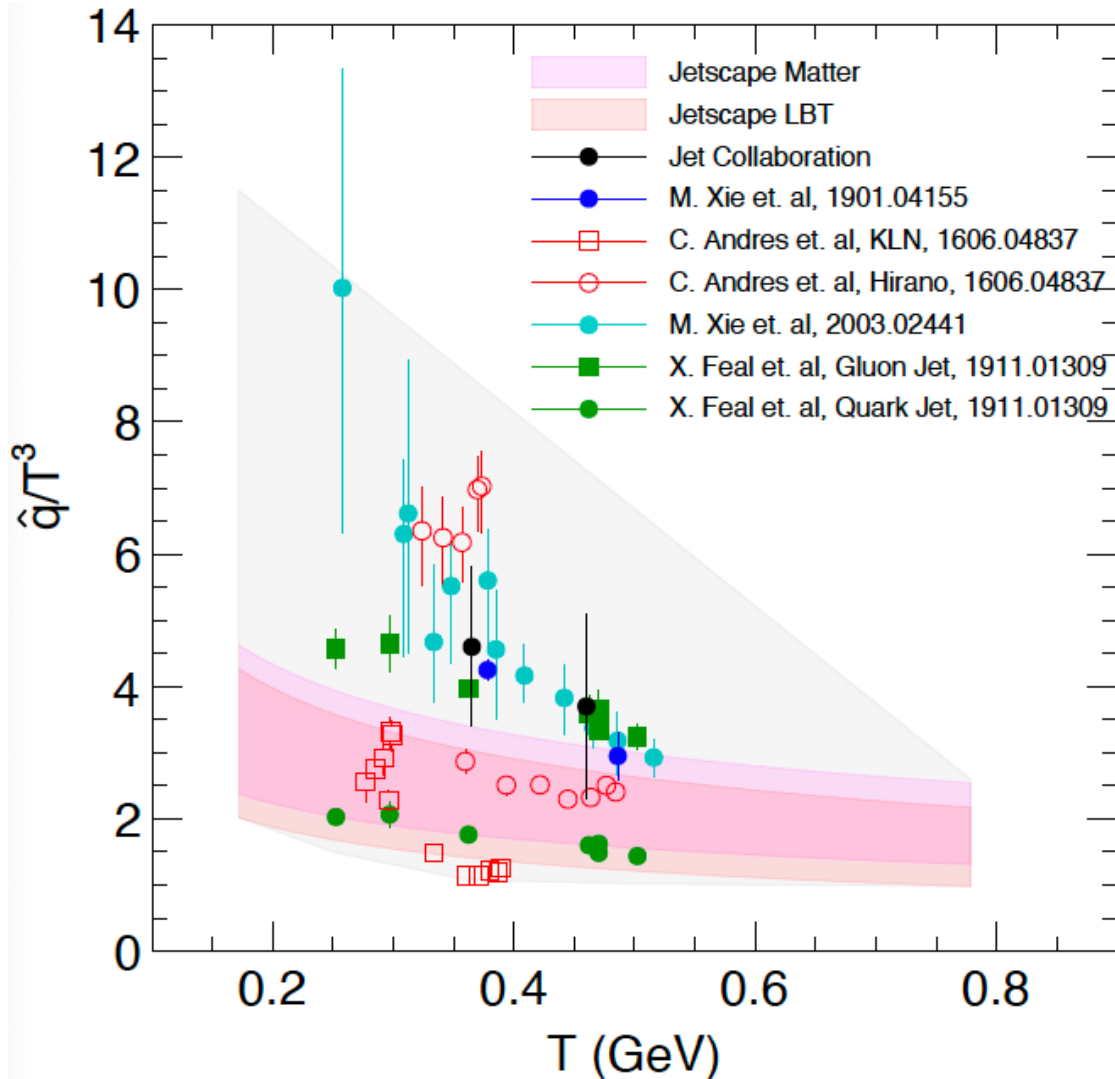

Cao, Wang, [arXiv:2002.04028](https://arxiv.org/abs/2002.04028)

Apollinario, Lee, Winn, [arXiv:2203.16352](https://arxiv.org/abs/2203.16352)

Knowledge of the initial state plays a major role

# Quark interlude

---

up to now we only considered hadrons built with *up*, *down*, *strange* quarks  
...these are light, masses from a few MeV (*u*, *d*) to  $\sim 90$  MeV (*s*)

what about heavier ones?

...for instance *charm*, which weights about 1.2 GeV

produced in pairs ( $c\bar{c}$ ) in initial hard collisions,  $t \sim 1/(2m_c) \leq 0.1$  fm/*c*

preserve their identity throughout the evolution of the fireball

...ideal messengers of the early stage

# Charm production in p-Pb, Pb-Pb vs. pp

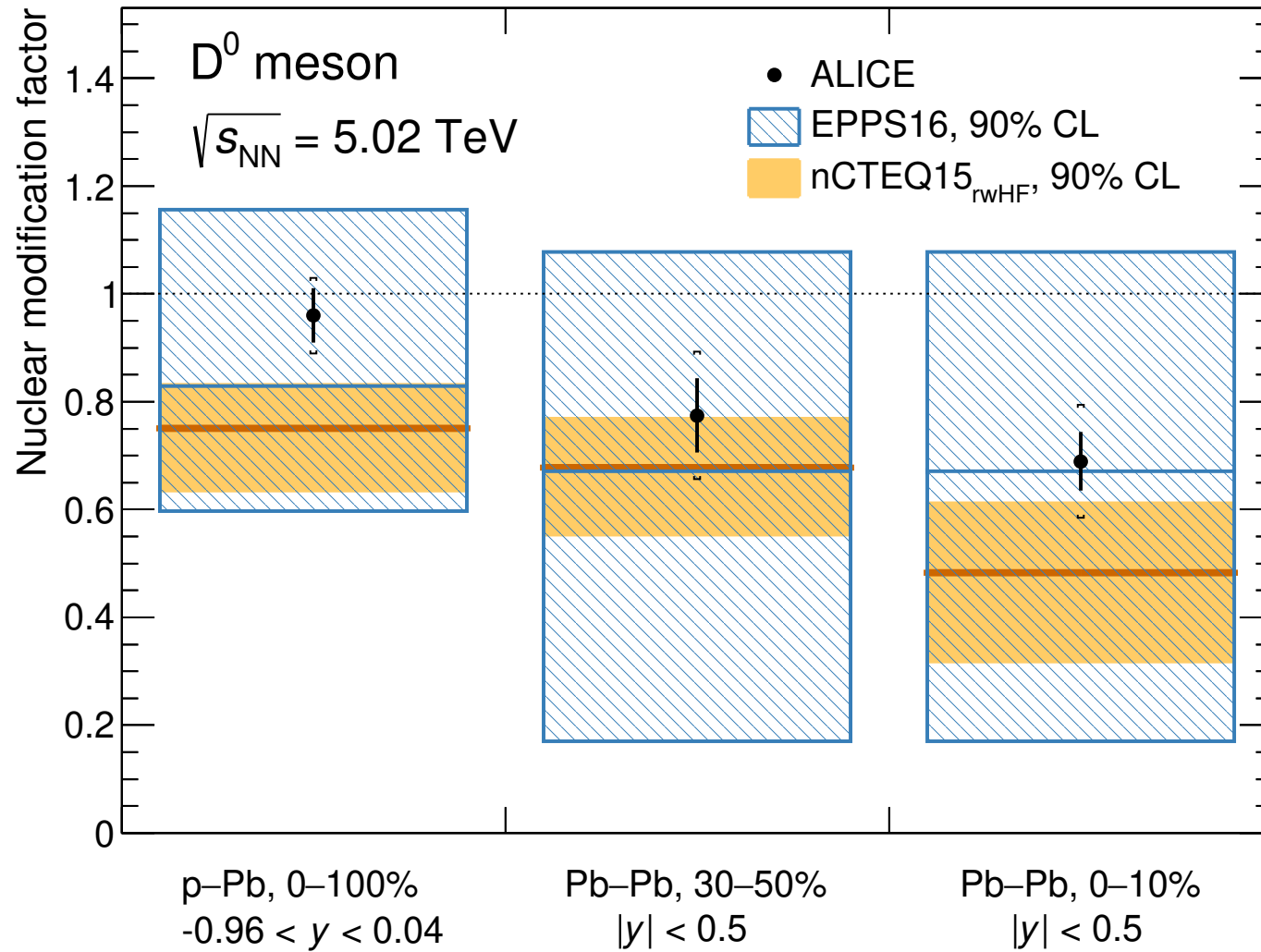

ALI-PUB-501940

# From charm quarks to hadrons

...an unsolved mystery

- Fragmentation,  $c \rightarrow D, D^*, D_s, \Lambda_c$  (empirical functions  $D_{c \rightarrow H_c}(z)$ )
- Coalescence / (re)combination,  $c + q \rightarrow D, c + q + q \rightarrow \Lambda_c$   
in phase space (in momentum space, resonance recombination)
- Statistical hadronization (as for u,d,s quarks, at  $T_{CF}$ )

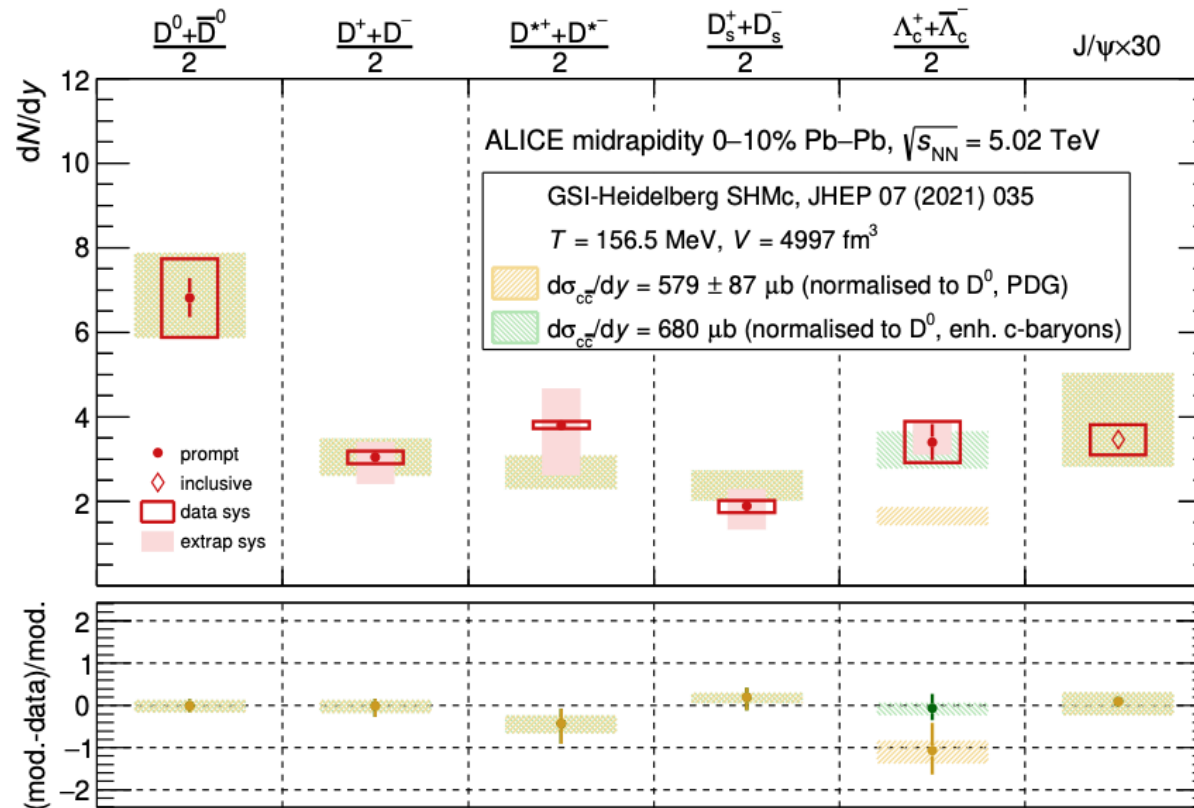

# Charm energy loss and flow: data and models

A. Andronic

29

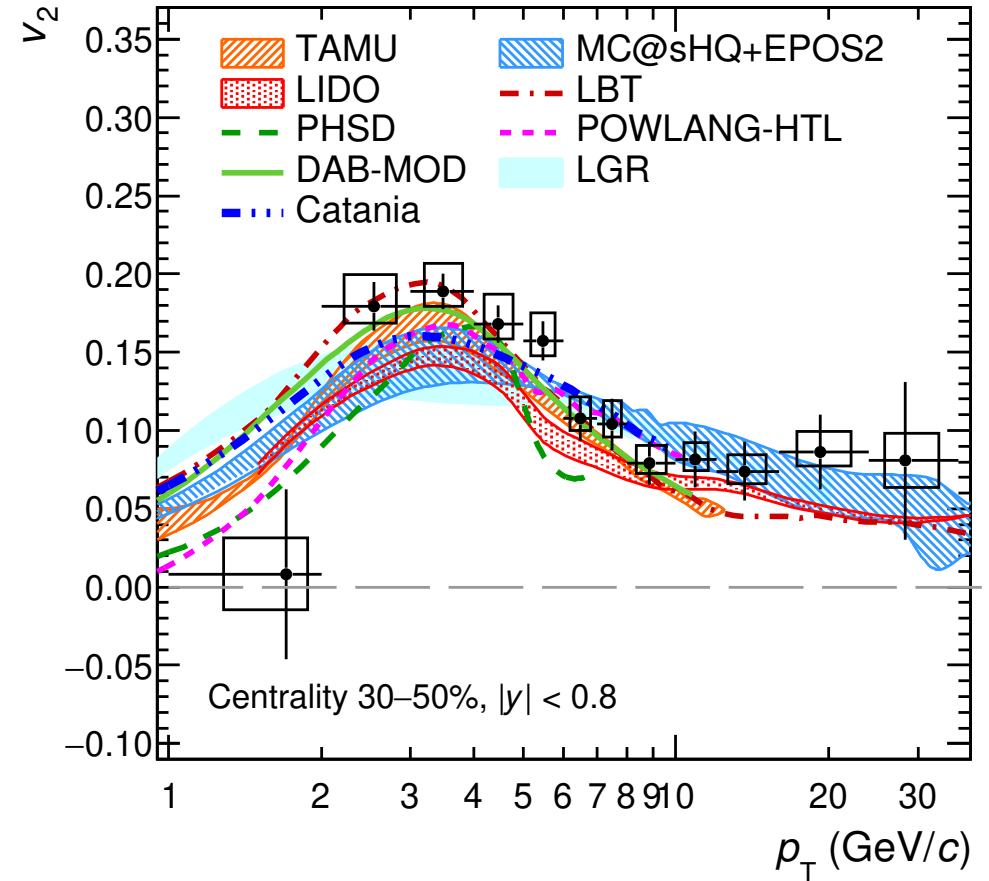
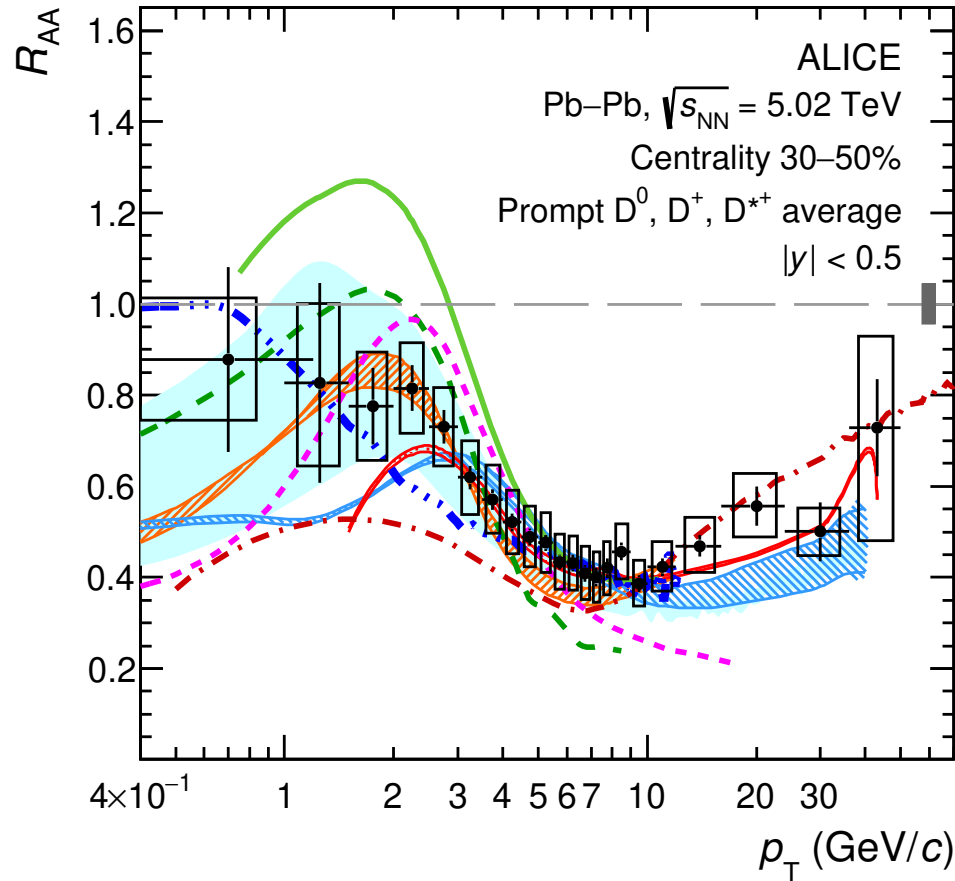

ALI-PUB-501956

ALICE, [arXiv:2110.09420](https://arxiv.org/abs/2110.09420)

In general a good description; a large variation of model results at low  $p_T$   
...theoretical uncertainties: nPDFs, hadronization

...some “unification” is being attempted ( [arXiv:1803.03824](https://arxiv.org/abs/1803.03824) )

# Charm spatial diffusion coefficient

key transport parameter (quantifies drag, thermal, recoil forces)

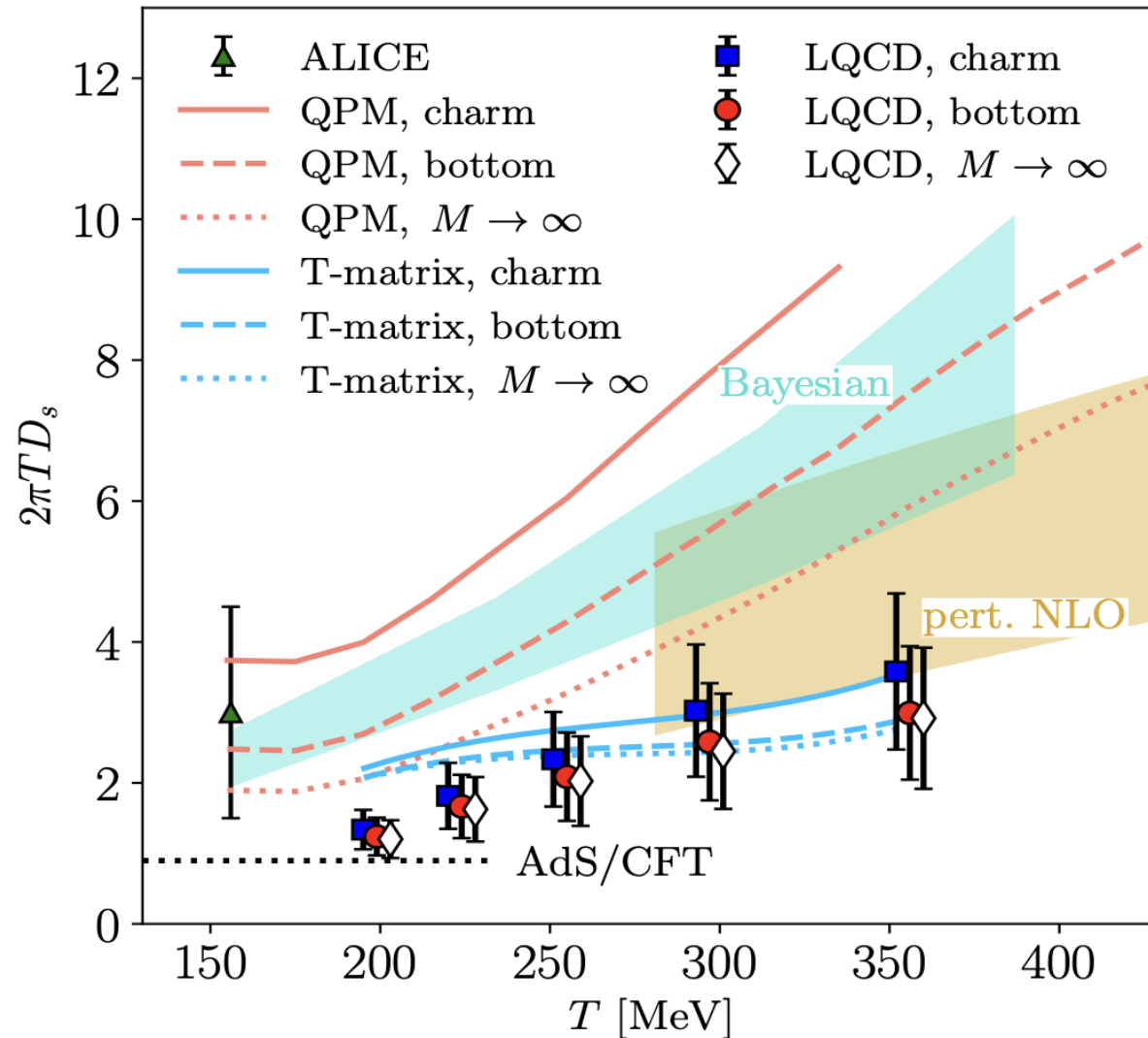

Altenkort et al., [PRL 132 \(2024\) 051902](#)

spatial diffusion coefficient  $D_s \simeq T^2/\hat{q}$ ;  $\hat{q} \sim T^3$

# Charmonium and deconfined matter

the original idea: Matsui & Satz, [Phys.Lett. B 178 \(1986\) 178](#)

*"If high energy heavy-ion collisions lead to the formation of a hot quark-gluon-plasma, then color screening prevents  $c\bar{c}$  binding in the deconfined interior of the interaction region."*

Refinements: "sequential suppression":

Digal, Satz, Petrecky, [PRD 64 \(2001\) 75](#)

Karsch, Kharzeev, Satz, [PLB 637 \(2006\) 75](#)

no  $q\bar{q}$  bound state if

$$r_{q\bar{q}}(T) > r_0(T) \simeq 1/(g(T)T)$$

$r_0$  Debye length in QGP

$\Rightarrow q\bar{q}$  "thermometer" of QGP

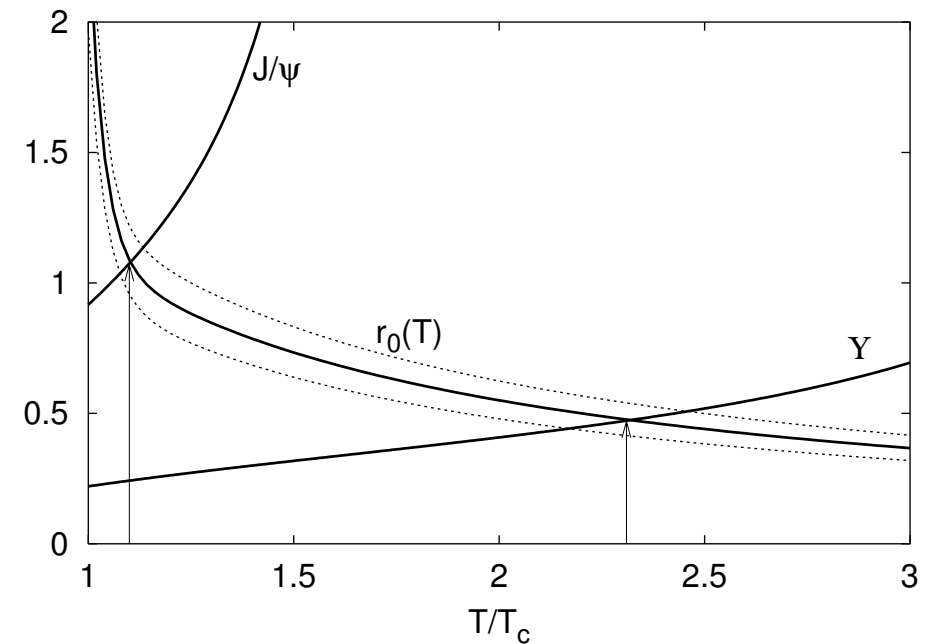

Thermal picture ( $n_{partons} = 5.2T^3$  for 3 flavors)

for  $T=500$  MeV:  $n_p \simeq 84/\text{fm}^3$ , mean separation  $\bar{r}=0.2$  fm  $< r_{J/\psi}$



# Charmonium data at RHIC and the LHC

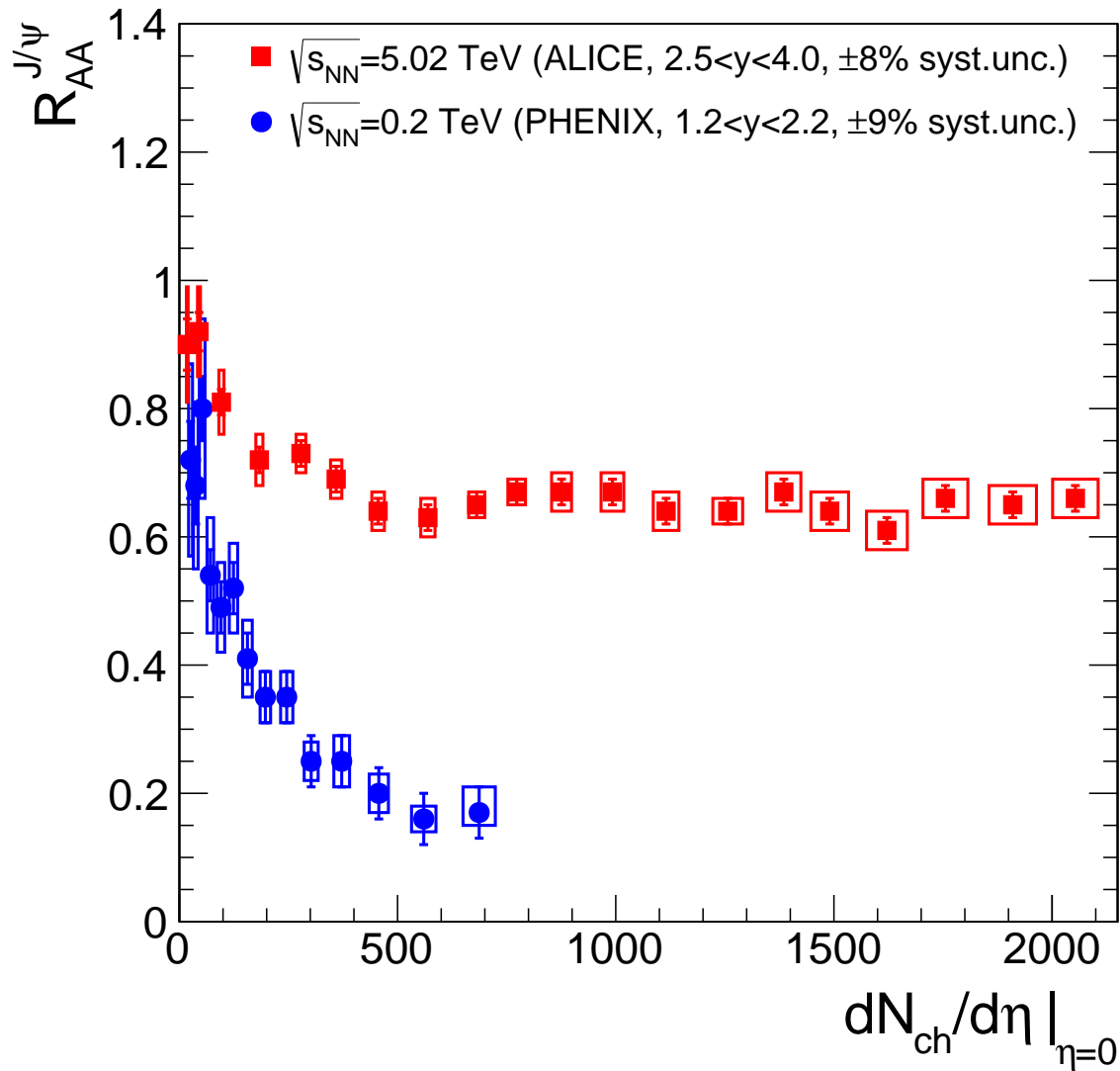

- "suppression" at RHIC (PHENIX)
- dramatically different at the LHC

$$dN_{ch}/d\eta \sim \varepsilon \quad (>20 \text{ GeV}/\text{fm}^3, \text{ for } dN_{ch}/d\eta \simeq 2000)$$

# Charmonium data at RHIC and the LHC

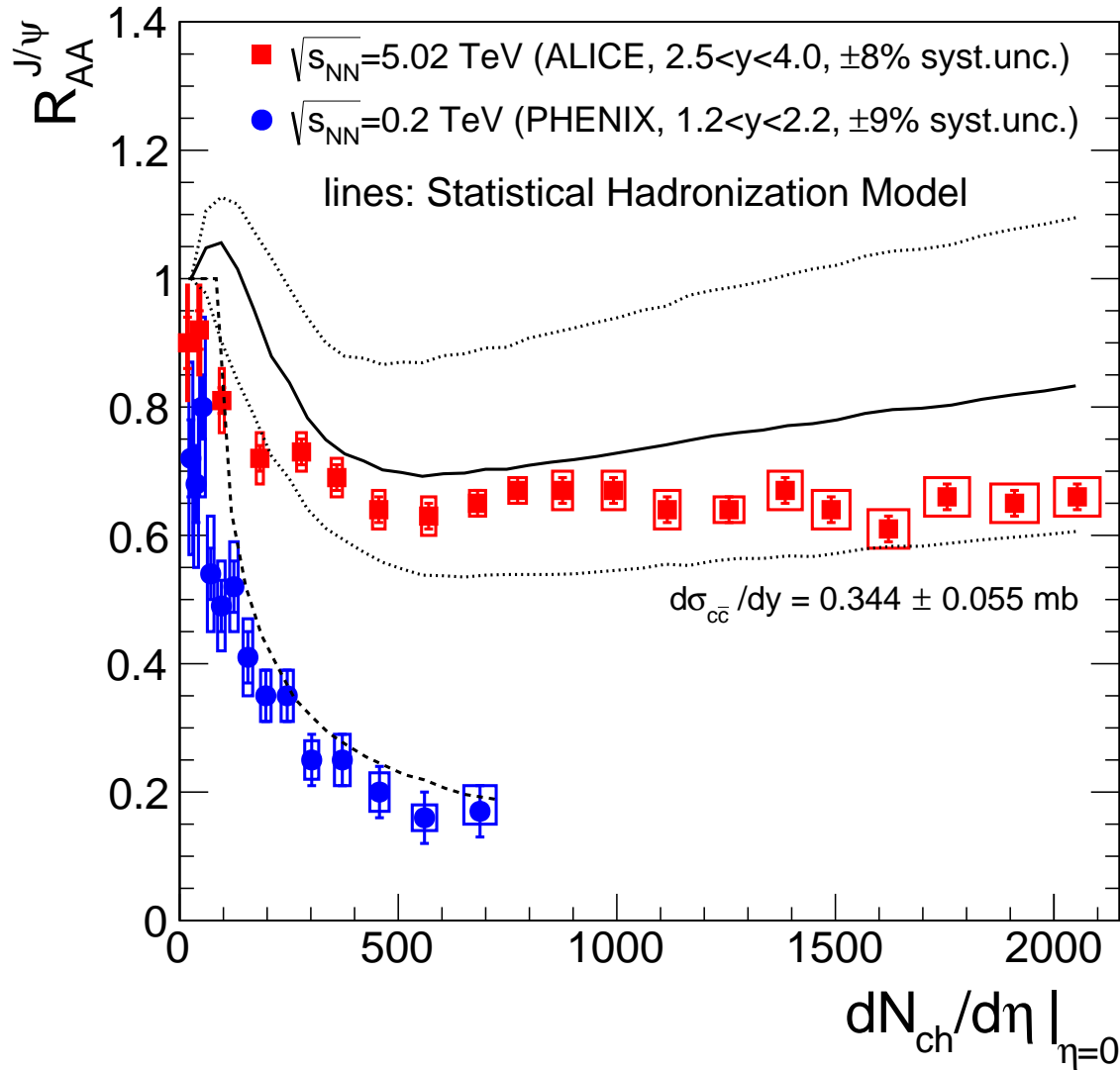

- "suppression" at RHIC (PHENIX)
- dramatically different at the LHC

Statistical Hadronization Model

$$N_{J/\psi} \sim (N_{c\bar{c}}^{dir})^2$$

$J/\psi$  is another observable (charm)  
for the phase boundary  
*calculations are for  $T=156 \text{ MeV}$*

$$dN_{ch}/d\eta \sim \varepsilon \text{ (} > 20 \text{ GeV/fm}^3, \text{ for } dN_{ch}/d\eta \simeq 2000 \text{)}$$

# Quark matter in neutron stars?

A. Andronic

43

## DENSE MATTER

Neutron stars get denser with depth. Although researchers have a good sense of the composition of the outer layers, the ultra-dense inner core remains a mystery.

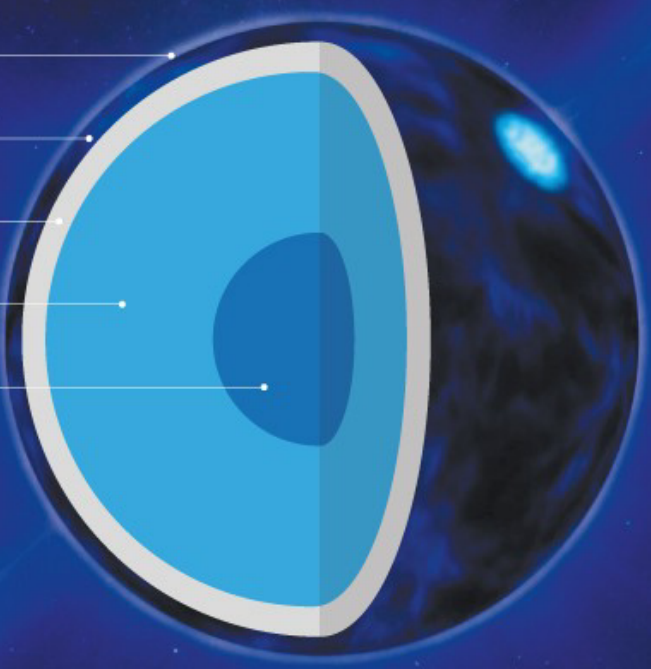

1. Atmosphere
2. Outer crust
3. Inner crust
4. Outer core
5. Inner core

1. Atmosphere	Mostly hydrogen and helium
2. Outer crust	Atomic nuclei and free electrons
3. Inner crust	Free neutrons and electrons, heavier atomic nuclei
4. Outer core	Neutron-rich quantum liquid
5. Inner core	Unknown, ultra-dense matter

## Core scenarios

A number of possibilities have been suggested for the inner core, including these three options.

- u Up quark
- s Strange quark
- d Down quark
- $\bar{d}$  Anti-down quark

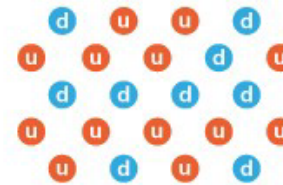

## Quarks

The constituents of protons and neutrons — up and down quarks — roam freely.

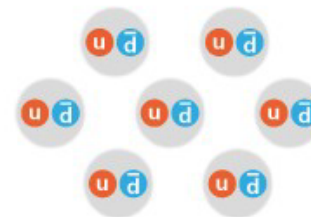

## Bose-Einstein condensate

Particles such as pions containing an up quark and an anti-down quark combine to form a single quantum-mechanical entity.

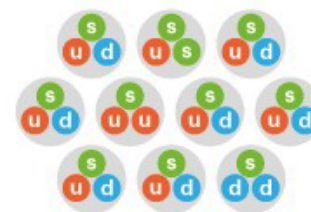

## Hyperons

Particles called hyperons form. Like protons and neutrons, they contain three quarks but include 'strange' quarks.

©nature

A.Mann, [Nature 579 \(2020\) 20](#)

# The quark core in a neutron star ( $2M_{Sun}$ , $R=12$ km)

A. Andronic

44

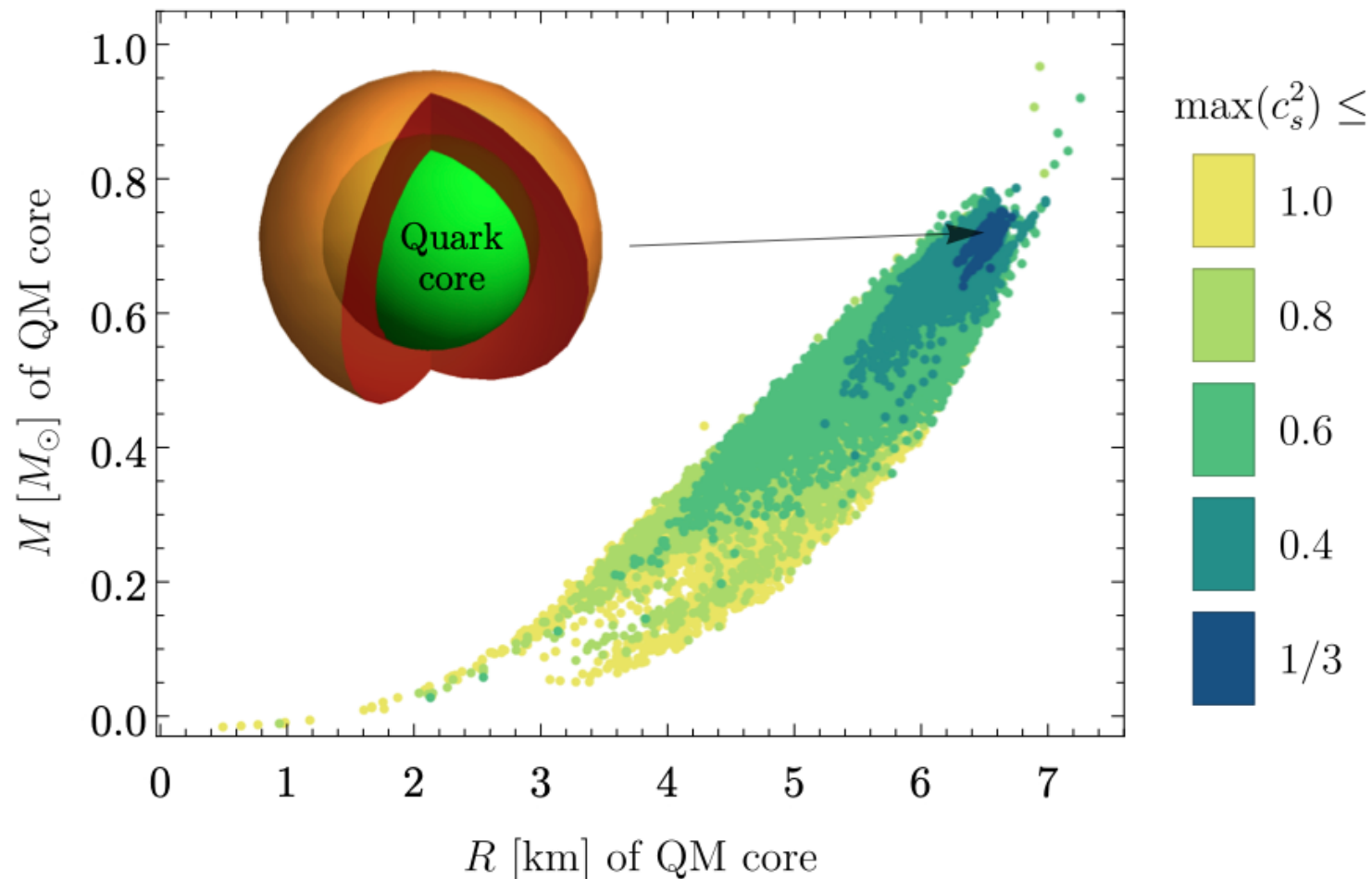

Theoretical calculations, Annala et al, [Nature Phys. 16 \(2020\) 907](#)

the closer to ideal gas ( $c_s^2 = 1/3$ ) quark matter is, the larger/heavier the core

NB: not the quark-gluon matter of LHC (antiquarks and gluons largely absent here; neutron star quark matter may be produced at FAIR/GSI)

# Summary

- nucleus-nucleus collisions are highly-dynamic  
...we establish observables for various stages
- abundance of hadrons with light quarks consistent with chemical equilibrium  
the thermal model provides a simple way to access the QCD phase boundary
- charmed hadrons and charmonium also (mostly) produced at phase boundary  
... from  $c\bar{c}$  pairs (largely) thermalized in QGP  
bottomonium suppression observed; bottom thermalization still open
- strong collective flow, well described by hydrodynamics  
the derived energy, entropy densities (initial and averaged) are well above the values expected for deconfinement  
early (rapid) thermalization remains not fully understood
- we see strong jet quenching (parton energy loss) in quark-gluon matter  
data + theoretical models  $\rightarrow$  extraction of transport coefficients

# What lies ahead (the next 10 years)

---

Precision characterization of quark-gluon matter at LHC in Run 3, 4

LHC detectors with major upgrades (ATLAS, CMS major upgrades in LS3)

Interestingly: O-O (and p-O) collisions in 2025 (limits of jet quenching)

Measurements at BNL RHIC (STAR, sPHENIX) and FAIR (CBM)

# Extra slides

---

A. Andronic

# QCD EoS

A. Andronic

1

Kojo, *Universe* 4 (2018) 42, Baym et al., *RPP* 81 (2018) 056902

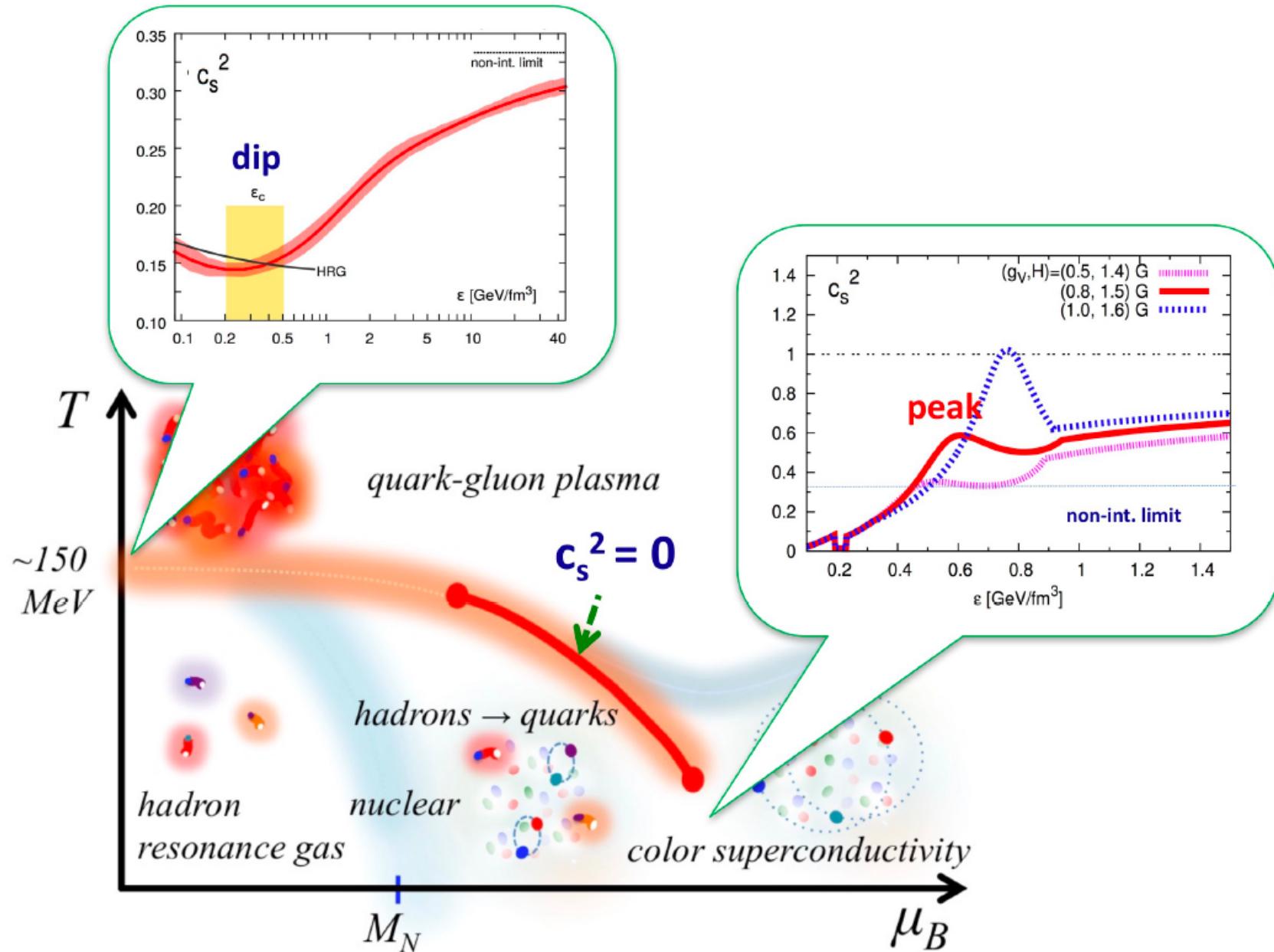



# Counting charged particles

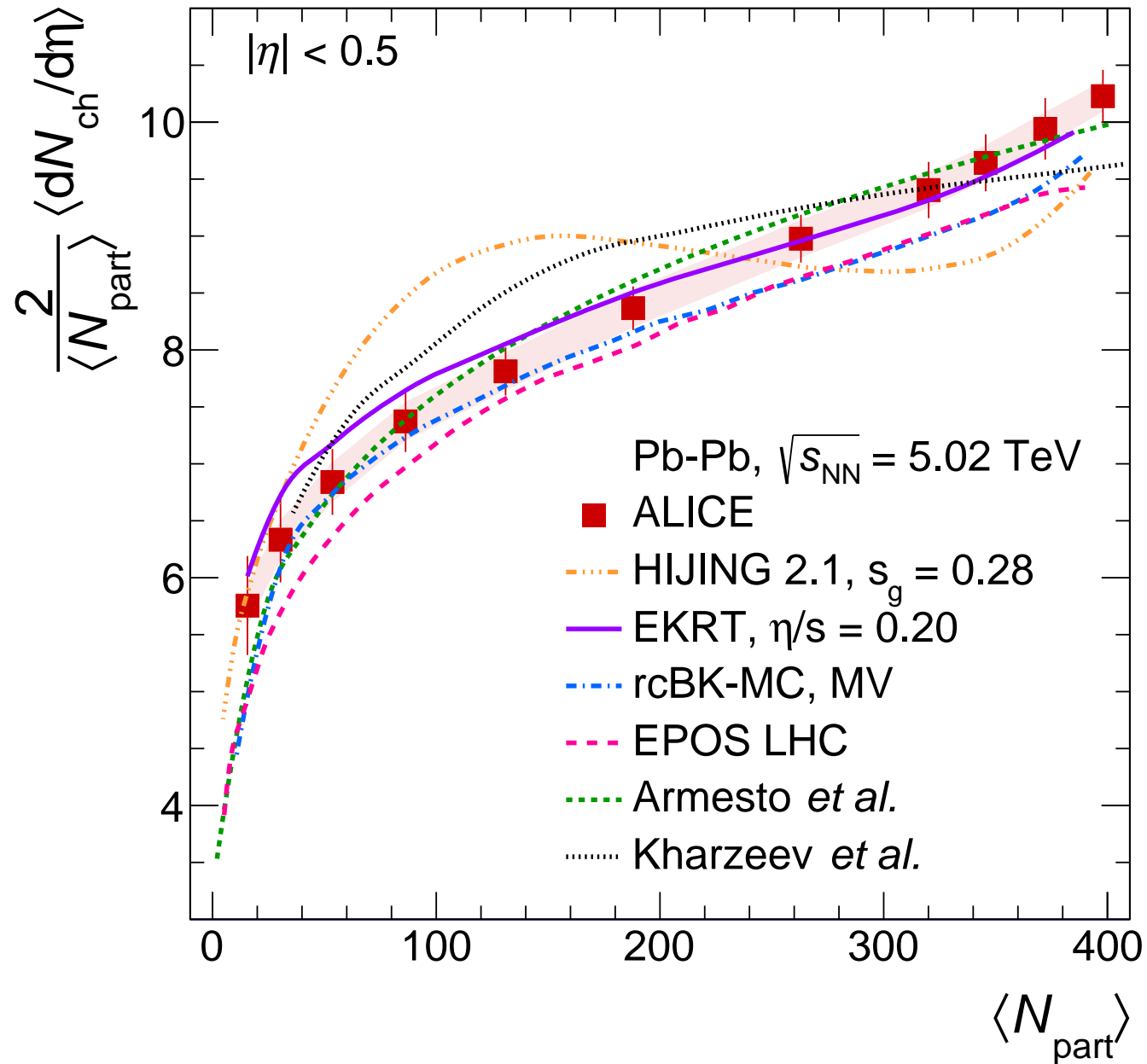

# Nucleus-nucleus collisions: energy density

A. Andronic

3

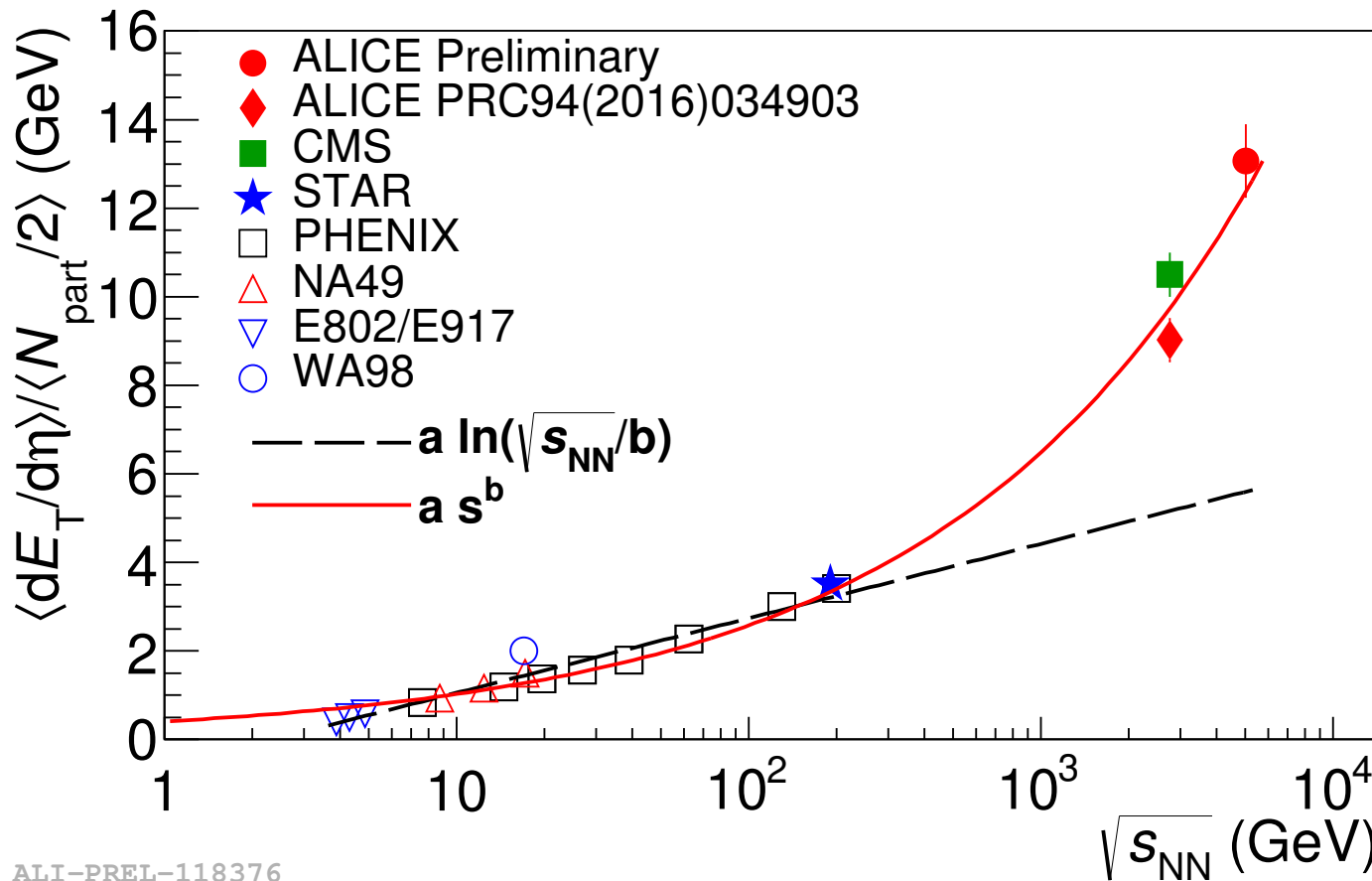

$E_T$ : transverse energy  
(energy built from  $p_T$ )

$\varepsilon_{LHC} \simeq 20 - 40 \text{ GeV}/\text{fm}^3$   
(much above  $\varepsilon_c$ )

$\varepsilon_{FAIR} \lesssim 1 \text{ GeV}/\text{fm}^3$   
(around  $\varepsilon_c$ )

ALI-PREL-118376

self-similar (Hubble-like) homogeneous (hydrodynamic) expansion of the fireball in the longitudinal (beam) direction  
("Bjorken model", 1983)

Energy density: 
$$\varepsilon = \frac{1}{A_T} \frac{dE_T}{dy} \frac{1}{c\tau_0}$$

-  $A_T = \pi R^2$ : transverse area (Pb-Pb:  $A_T = 154 \text{ fm}^2$ )

-  $\tau_0 \simeq 1 \text{ fm}/c$ : formation time (establishing the equilibrium) ... *not measurable!*

# Hadron yields at midrapidity (central collisions)

A. Andronic

4

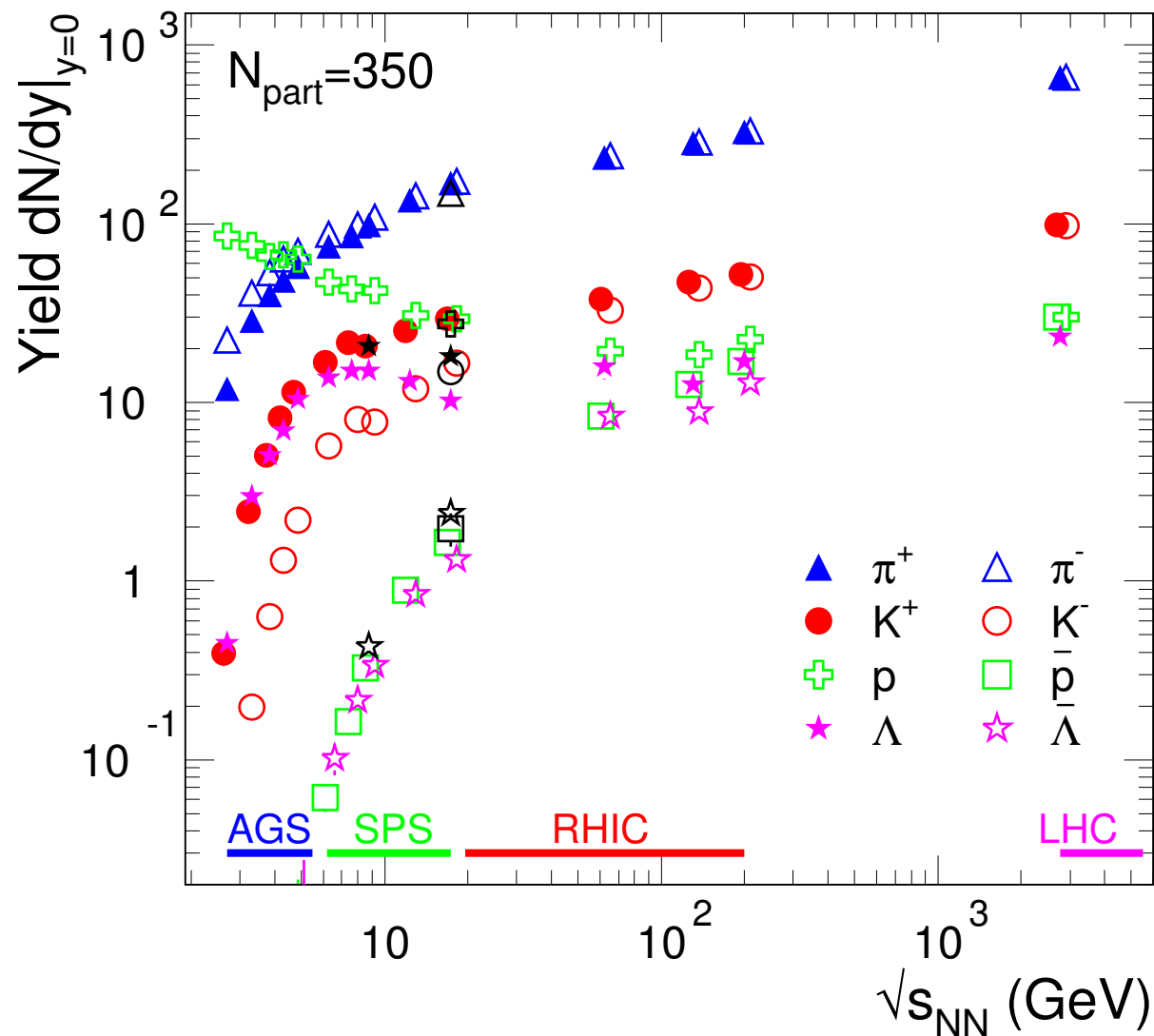

- lots of particles, mostly newly created ( $m = E/c^2$ )
- a great variety of species:
  - $\pi^\pm$  ( $u\bar{d}$ ,  $d\bar{u}$ ),  $m=140$  MeV
  - $K^\pm$  ( $u\bar{s}$ ,  $\bar{u}s$ ),  $m=494$  MeV
  - $p$  ( $uud$ ),  $m=938$  MeV
  - $\Lambda$  ( $uds$ ),  $m=1116$  MeV
  - also:  $\Xi(dss)$ ,  $\Omega(sss)$ ...
- mass hierarchy in production at high energies ( $e^{-m/T}$ )

AA, [arXiv:1407.5003](https://arxiv.org/abs/1407.5003)

at lower energies:  $u, d$  quarks as "remnants" (stopped) from the incoming nuclei

# Viscosity and fluidity

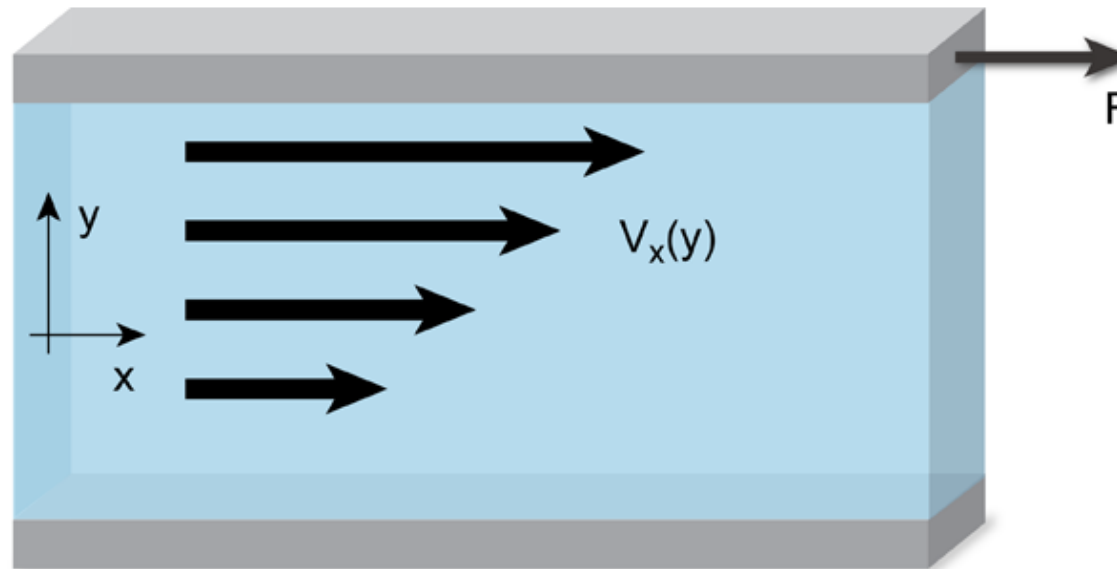

Illustration: Carin Cain

Figure 1: Viscosity—the ratio between a shear force  $F$  and the transverse gradient in a velocity profile  $\nabla_y v_x$ —causes dissipation in a fluid, which converts part of the kinetic energy in the flow to heat. A "good" fluid is therefore characterized by a small shear viscosity.

$$\frac{F}{A} = \eta \nabla_y v_x, \quad \eta \text{ shear viscosity (in Pa}\cdot\text{s)}$$

Good fluidity: large Reynolds numbers  $Re = \frac{mn}{\eta} vL$  ( $\eta/n$  in  $\hbar$ )

For relativistic fluids ( $n$  not constant):  $\eta/(\hbar n) \rightarrow \eta/s$  (in  $\hbar/k_B$ )

$s$  entropy density

# Data and hydrodynamics

A. Andronic

6

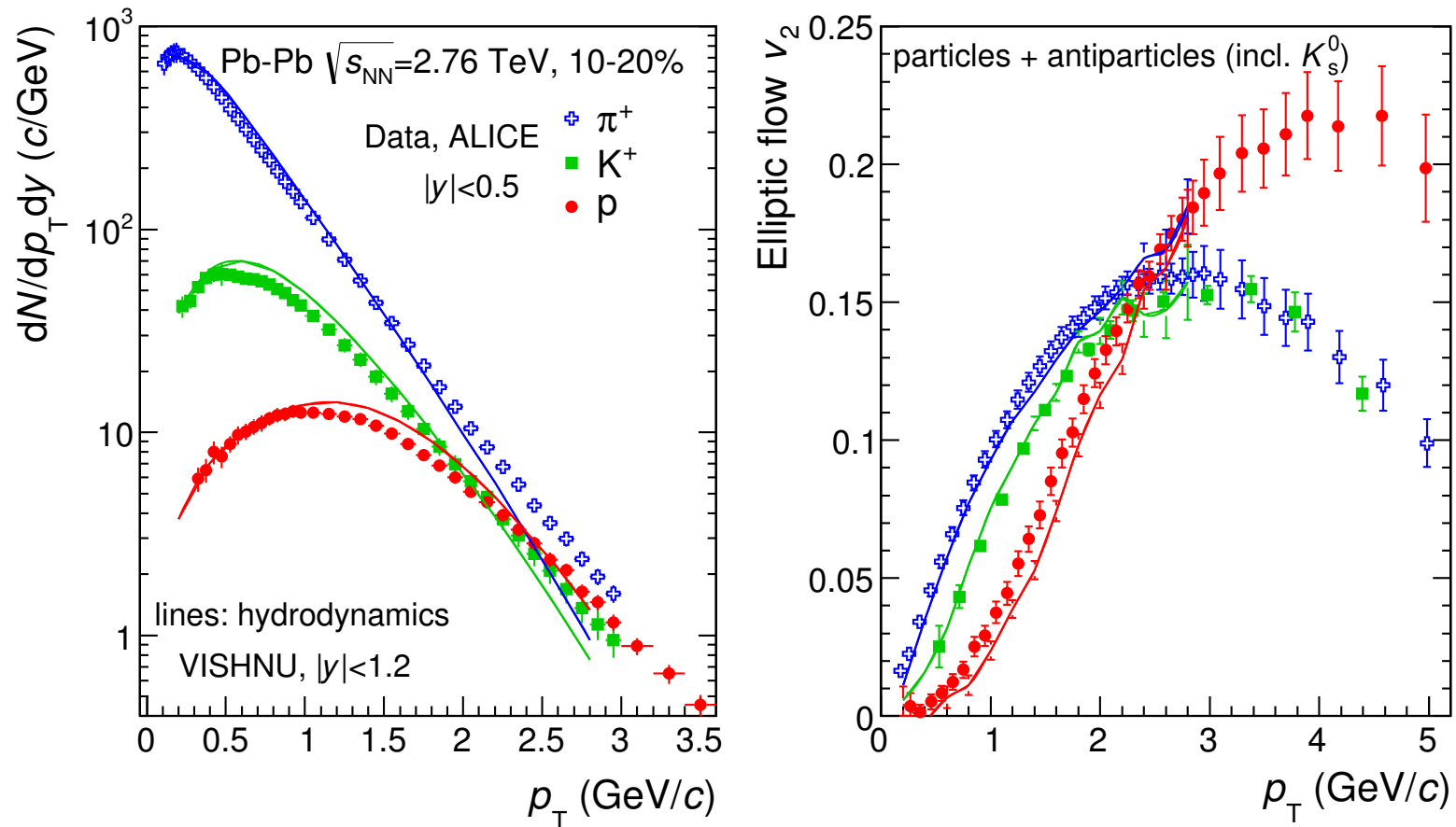

mass dependence due to collective flow

hydrodynamic models reproduce the data with a very small ratio  $\eta/s$   
viscosity/entropy density,  $\eta/s \sim T\lambda c_s$

lower bound conjectured (AdS/CFT):  $\eta/s \geq 1/4\pi$  Kovtun, Son, Starinets, [hep-th/0405231](https://arxiv.org/abs/hep-th/0405231)

# Elliptic flow: energy dependence

A. Andronic

7

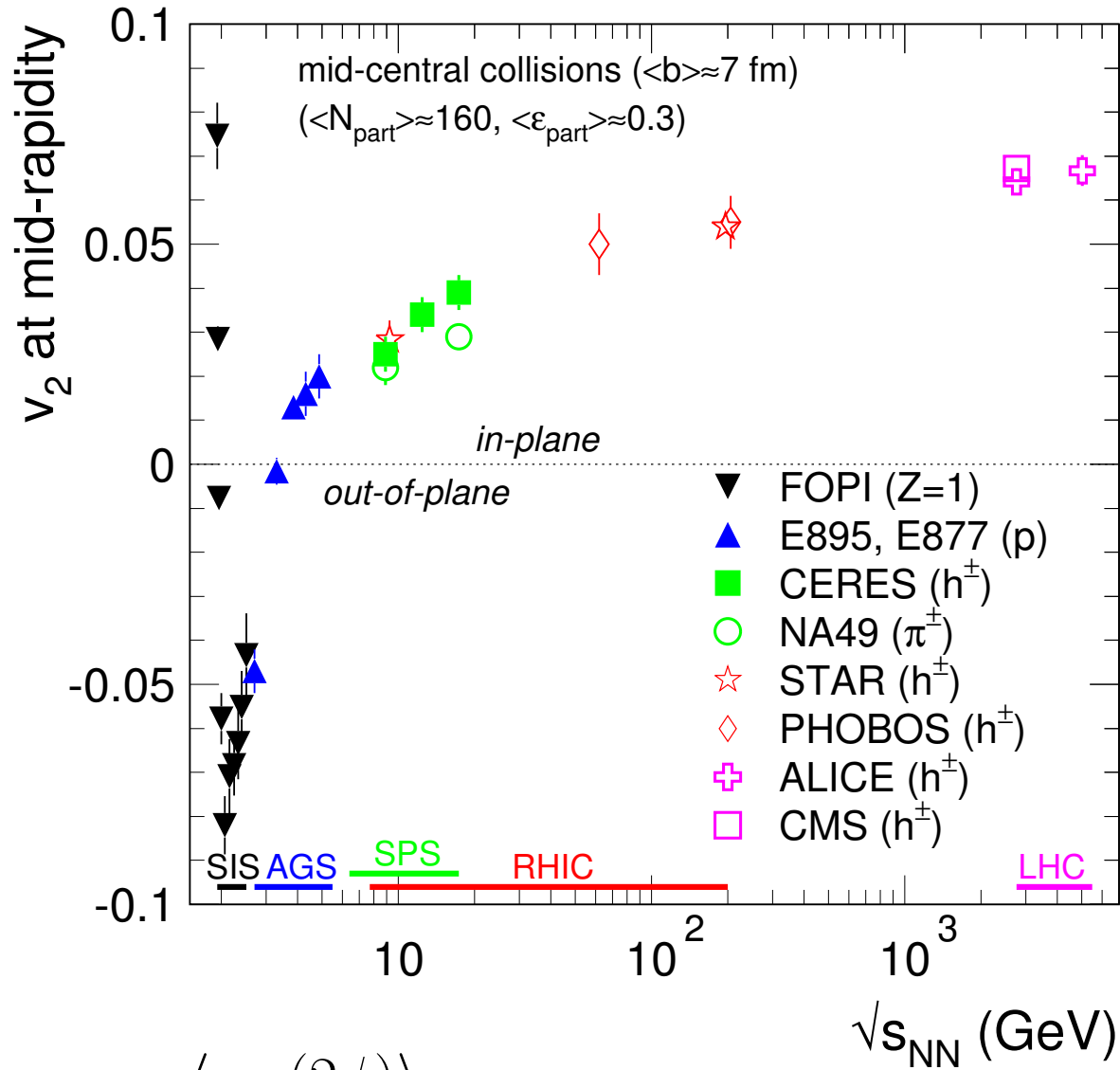

$$v_2 = \langle \cos(2\phi) \rangle$$

## 3 regimes:

$v_2 > 0$  at low energies: in-plane, rotation-like emission

$v_2 < 0$  onset of expansion, in competition with shadowing by spectators (which act as a clock for the collective expansion,  $t_{\text{pass}} = 40-10$  fm/c)

$v_2 < 0$  at high energies: “free” fireball (almond-shape) expansion (“genuine” elliptic flow)

hydrodynamic description, low  $\eta/s$

# Dileptons: the temperature

A. Andronic

8

...averaged over the space-time history (evolution) of the fireball

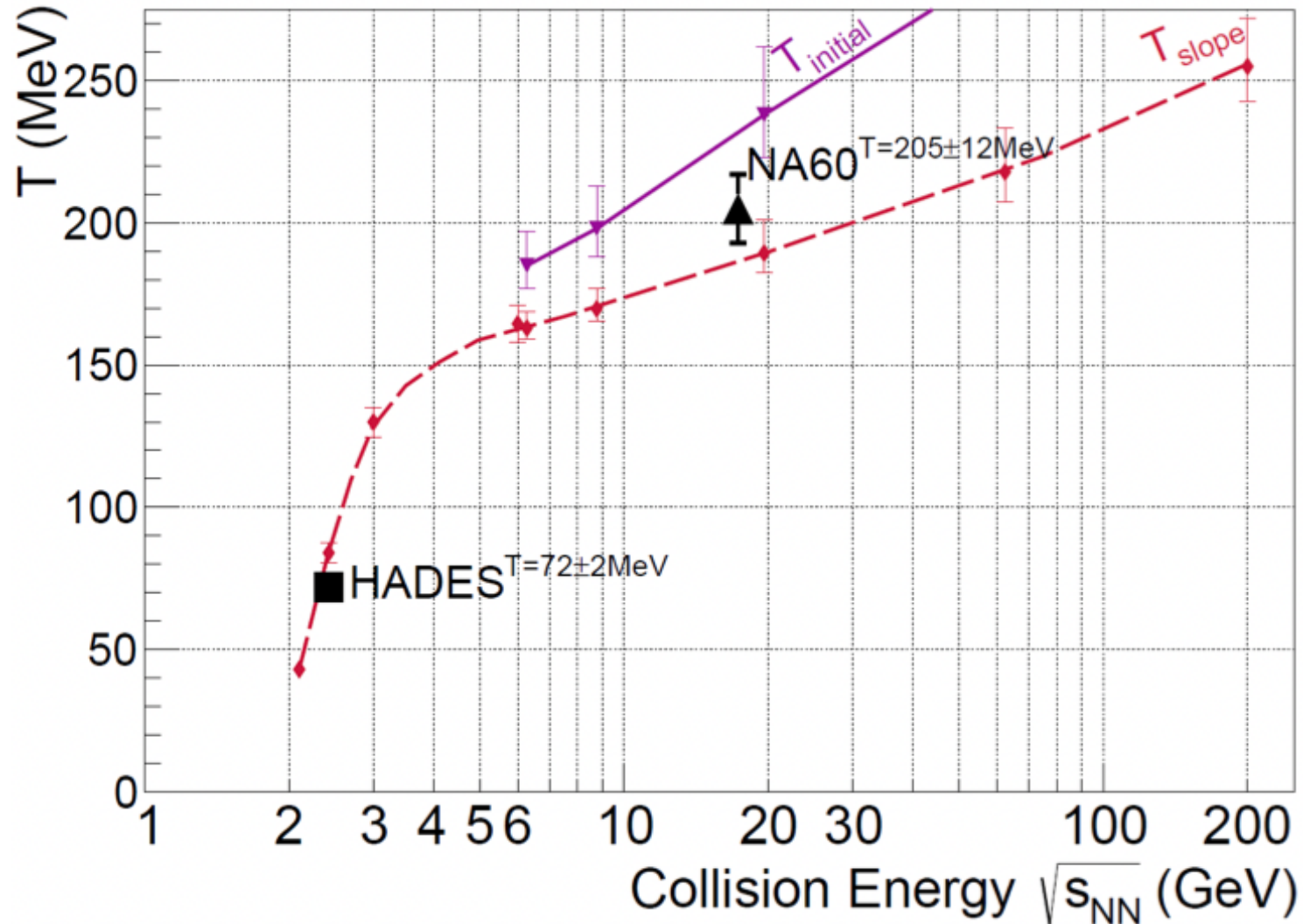

# The light and the heavy quarks

A. Andronic

9

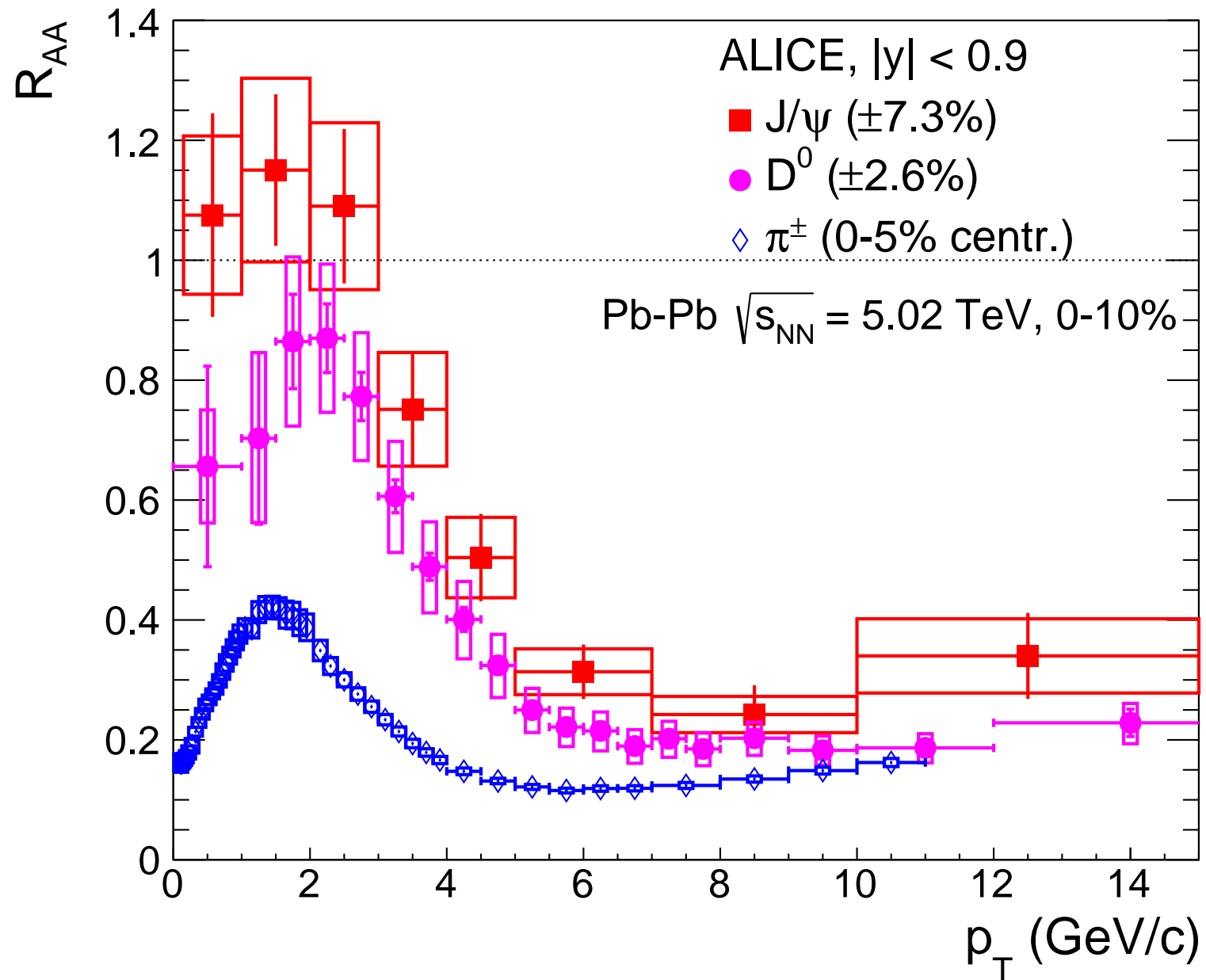



# Nuclear modification: a sketch

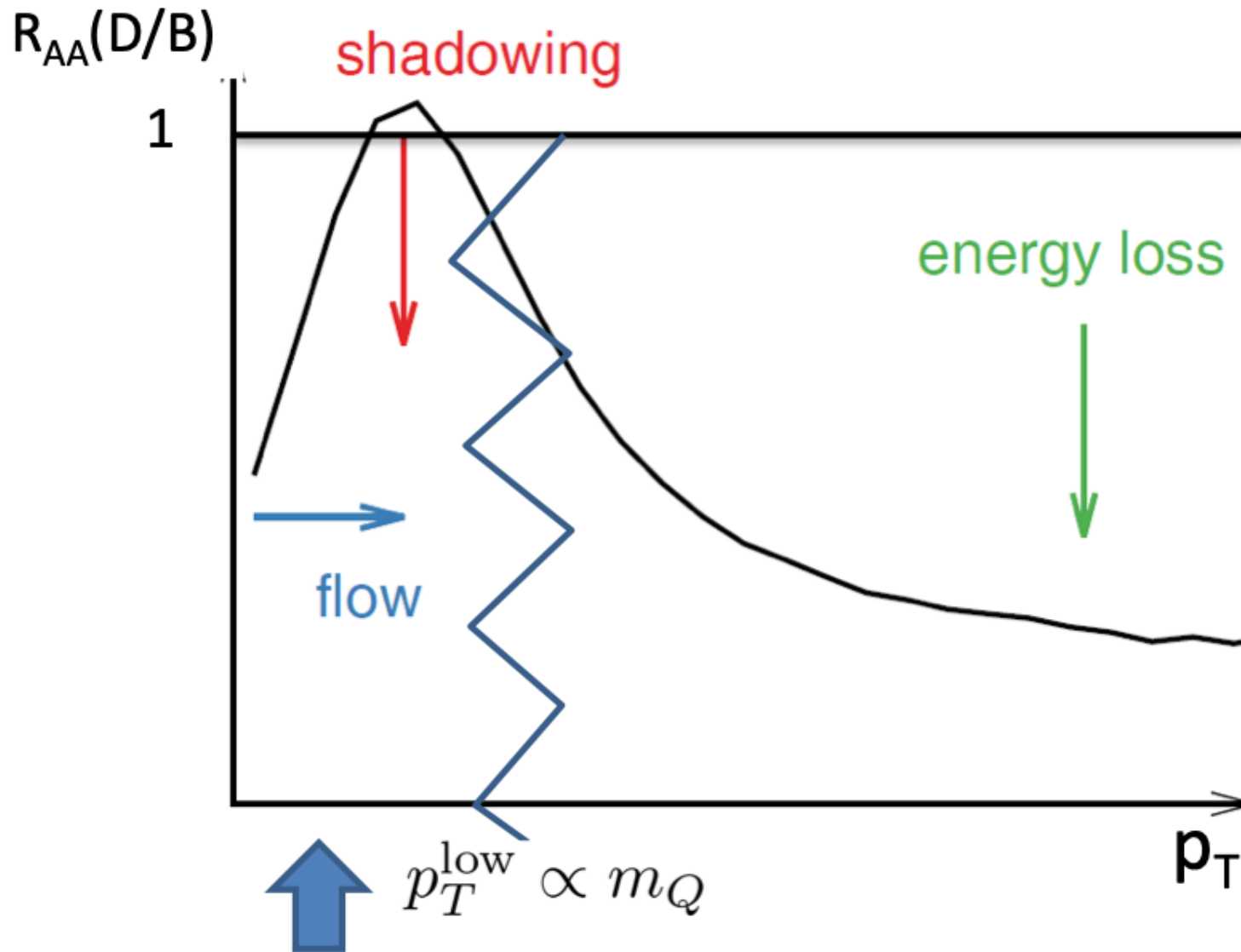

# Heavy quark energy loss: data and models

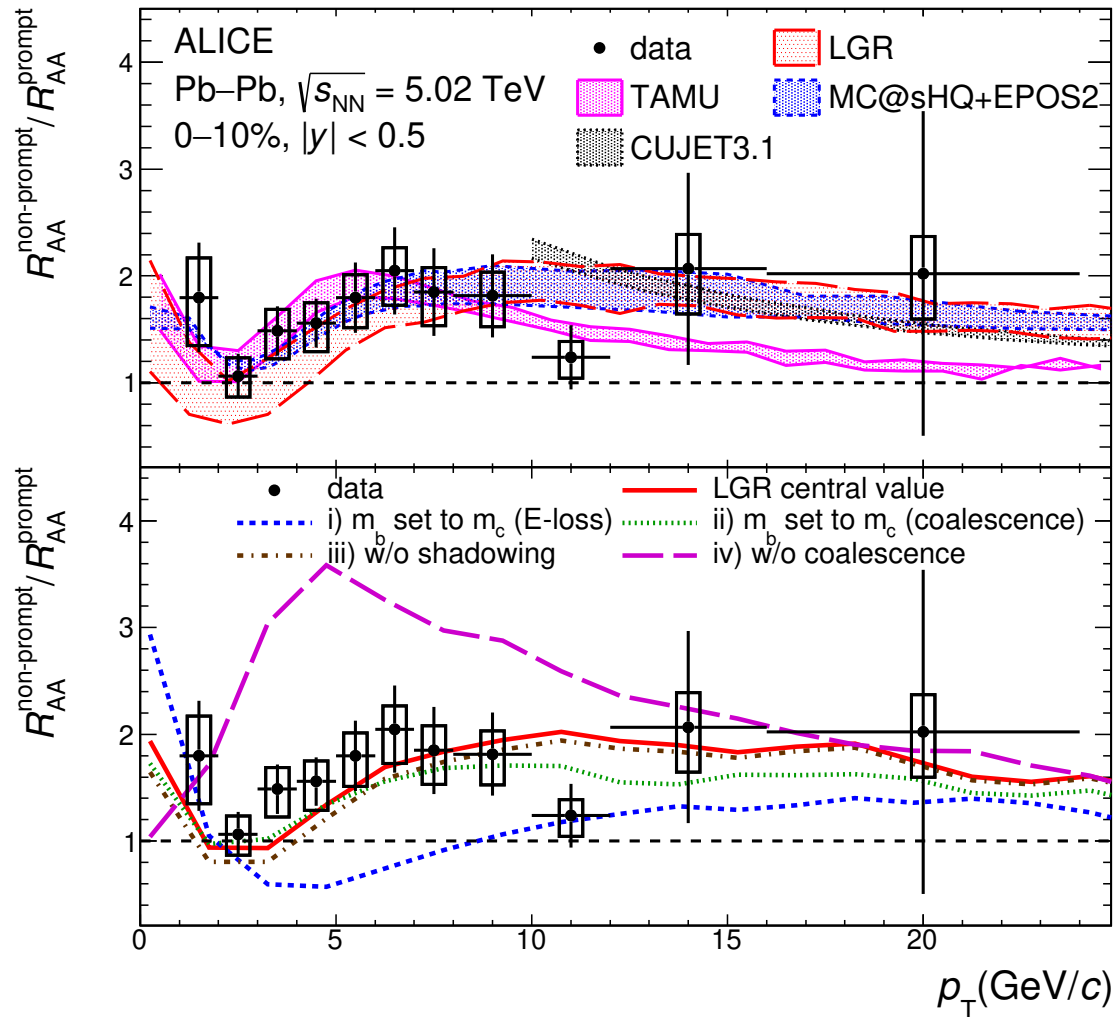

b quarks (*non-prompt*  $D^0$ ) are less suppressed than c quarks (*prompt*  $D^0$ )

dead cone effect:

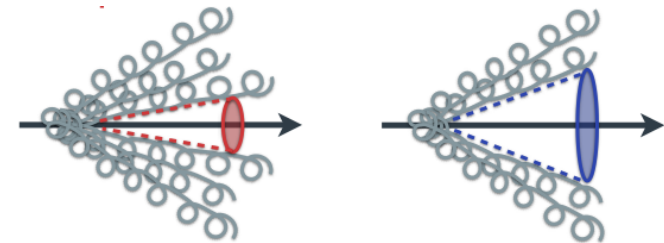

©F.Grosa

$$\Delta E_b < \Delta E_c < \Delta E_{u,d,s}$$

Models describe data ...but not in a perfect agreement

# Transport models - schematics

A. Andronic

12

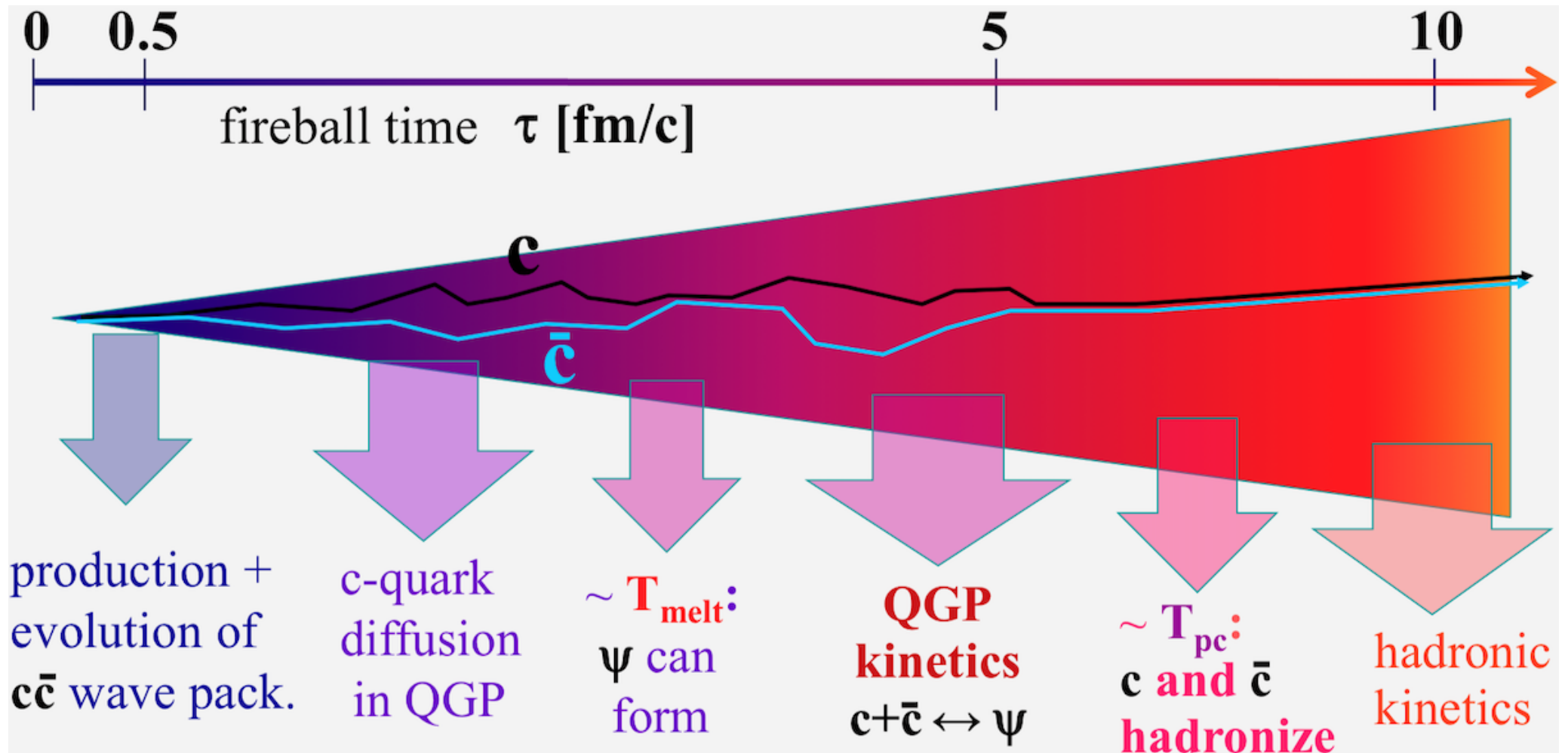

Rapp, Du, [arXiv:1704.07923](https://arxiv.org/abs/1704.07923)

Low  $p_T$ : Brownian motion (diffusion) of charm (and b) quarks in QGP

example is for  $J/\psi$ , same picture for  $D$ ,  $\Lambda_c$  (except light quarks 'join' late)

$$\frac{\partial f_Q}{\partial t} = \frac{\partial}{\partial p} \left( A(p) p f_Q + B(p) \frac{\partial f_Q}{\partial p} \right) \simeq \frac{\partial (A(p) p f_Q)}{\partial p} + B \Delta_{\vec{p}} f_Q$$

Fokker-Planck equation for HQ phase-space distribution  $f_Q(t, \vec{p})$

special case of Boltzmann eq., for  $p^2 \sim m_Q T \gg T^2$  ( $m_Q/T \geq 5$ )

- $A$ : drag coeff. / thermalization rate; thermal relaxation time  $\tau_Q = 1/A(p=0)$
- $B$  momentum diffusion coefficient; *Einstein relation*:  $B(p) = A(p) m_Q T$
- Spatial diffusion constant:  $D_s = \frac{T}{A(p=0) m_Q}$ ;  $\langle x^2 \rangle - \langle x \rangle^2 = 6 D_s t$
- Relation to QCD medium:  $D_s(2\pi T) \sim \eta/s(4\pi)$

”Effective” pQCD treatment; no single recipe/formalism, variety of models

$$\tau_c \simeq 2 \text{ fm}/c \text{ (NB: } \simeq 20 \text{ fm}/c \text{ in leading-order pQCD)}$$

# $\Upsilon$ production

A. Andronic

14

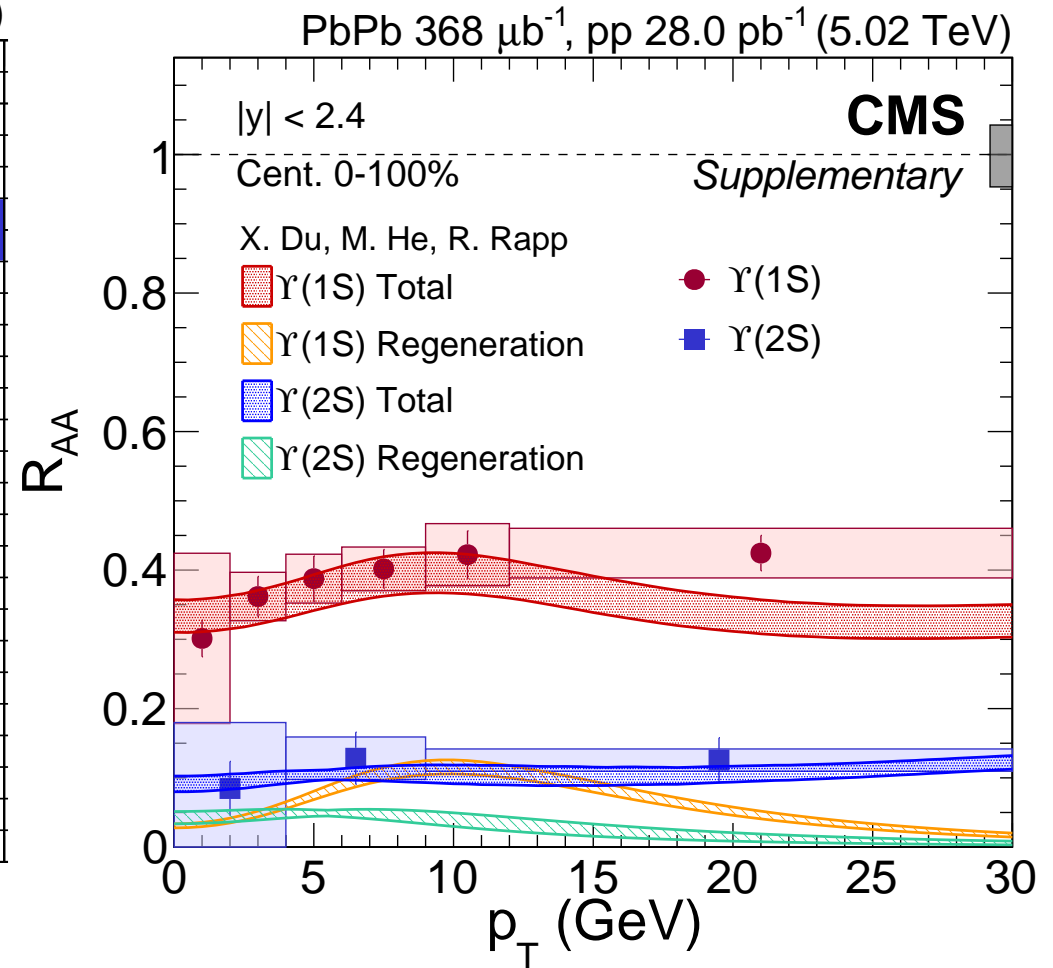
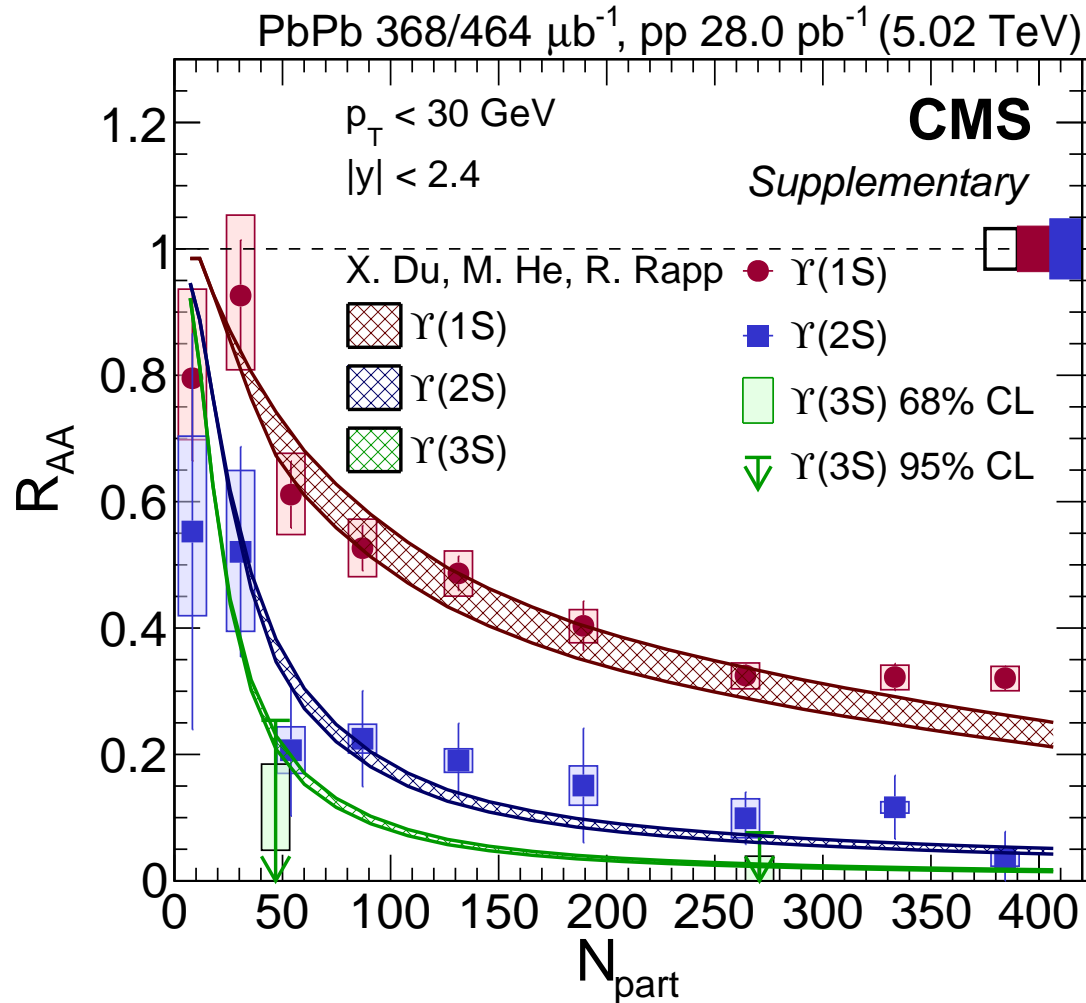

CMS, [arXiv:1805.09215](https://arxiv.org/abs/1805.09215)

$\Upsilon(1S)$  suppression to a large extent effect of feed-down from  $\Upsilon(2S, 3S)$ , which were fully dissociated (“sequential suppression”)